



magique totem

DESIGN
STUDIO KLASS
(M.MATURO E A.ROSCINI)

modello registrato
registered model

portata su ogni ripiano: 10 kg
load capacity on each shelf: 10 kg

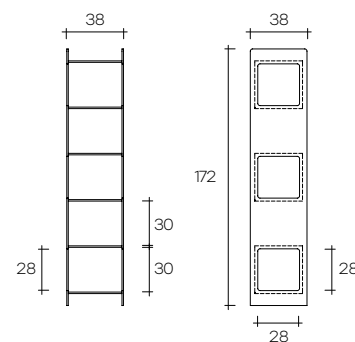

Espositore con cubi contenitori
in vetro saldato da 10 mm.
Disponibile in diverse finiture.

*Display cabinet with container cubes
in 10 mm-thick welded glass.
Available in various finishes.*

dimensioni L, P, H
dimensions L, W, H
(cm)

	COD./CODE	L	P/W	H	peso netto net weight (kg)	peso lordo gross weight (kg)	volume imballo package volume (m ³)
Espositore con struttura in vetro extralight, contenitori in vetro bianco opale (12 mm). <i>Display cabinet with extralight glass frame, opal white glass containers (12 mm thick).</i>	MQ/172XB	38	38	172	77,5	99,5	0,50
Espositore con struttura in vetro extralight, contenitori in vetro fumè. <i>Display cabinet with extralight glass frame, smoked grey glass containers.</i>	MQ/172XG	38	38	172	64	86	0,50
Espositore con struttura in vetro fumè, contenitori in vetro Nero95. <i>Display cabinet with smoked grey glass frame, Black95 glass containers.</i>	MQ/172GN	38	38	172	64	86	0,50

FINITURE
FINISHES

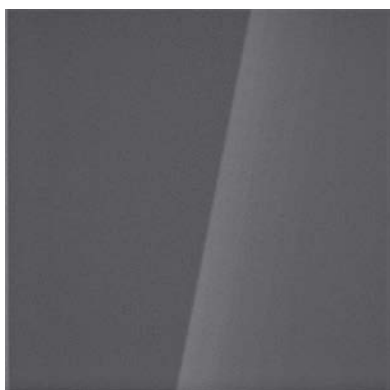
Struttura
Structurevetro extralight
extralight glass**Cubo contenitore**
Cubic inner compartmentvetro bianco opale
opal white glass**Struttura**
Structurevetro fumè
smoked glass**Cubo contenitore**
Cubic inner compartmentvetro Nero95
Black95 glass