

La forma dell'invisibile

Fiam Design Journey - 2026



FIAM

La forma dell'invisibile

Fiam Design Journey - 2026

FIAM



7

Ispirazioni e concept

Inspirations and concept

25

Le nuove collezioni

The new collections

26

Ogiva
tavolo, table

36

Trivium
tavolo, table

44

Brenta
sedia, chair

50

Still
specchio, mirror

60

Istante
specchio, mirror

68

Asteroids
tavolino, coffee table

76

Segesta Bar
madia, cupboard

82

Onair
poltrona, armchair

87

Dialoghi con lo spazio

Dialogues with space

104

Fiam Design Day - 2026

109

Schede tecniche

Technical data

It exists a material that does not occupy space – it reveals it. Glass, in its essence, is a joyful paradox: solid yet weightless, present and yet immaterial. To give form to the invisible means embracing the challenge of shaping light, of capturing the world's unexpected reflections and returning them as landscape, image, and sculpture.

Fiam Design Journey is born from this. It is not merely a catalogue, but the logbook of an annual encounter with inspiration.

A journey that begins at Villa Miralfiore, in Pesaro.

There, where history meets the future, international designers gathered to share the initial spark – the intimate, creative process that transforms a pure idea into tangible reality.

Within the Villa's rooms, a dialogue unfolded among diverse cultures, bound by a single intent: to bring to life a perceptual experience in which light, space, and the people who inhabit it speak to one another. These pages carry that same story forward.

Because every work signed by Fiam holds a secret: the perfect osmosis between the vision of the world's greatest creative minds and the hands of our artisans, who guide technology to give a body to the invisible.

Esiste una materia che non occupa lo spazio, ma lo rivela.

Il vetro, nella sua essenza, è un paradosso felice: solido ma leggero, presente eppure immateriale. Dare forma all'invisibile significa accettare la sfida di modellare la luce, di catturare i riflessi inattesi del mondo e restituirli sotto forma di paesaggio, immagine e scultura.

Fiam Design Journey nasce da qui. Non è solo un catalogo, ma il diario di bordo di un appuntamento annuale con l'ispirazione.

Un viaggio che parte da Villa Miralfiore, a Pesaro.

Lì, dove la storia incontra il futuro, i designer internazionali si sono riuniti per raccontare la scintilla iniziale, il percorso intimo e progettuale che trasforma un'idea pura in realtà tangibile.

Nelle sale della Villa è andato in scena un dialogo tra culture diverse, unito da un unico intento: dare vita a un'esperienza percettiva capace di far dialogare la luce, lo spazio e chi lo abita. In queste pagine si snoda quel medesimo racconto.

Perché ogni opera firmata Fiam racchiude un segreto: la perfetta osmosi tra la visione dei più grandi creativi del mondo e le mani dei nostri artigiani, capaci di guidare la tecnologia per dare un corpo all'invisibile.

Ispirazioni e concept

Inspirations and concept

Ogni grande viaggio comincia da un'intuizione invisibile, da un pensiero ancora libero che cerca la propria forma. Prima della materia, prima della tecnica, esiste il gesto creativo con cui i designer dà forma a nuove relazioni tra luce, superficie e spazio. È il momento più libero e autentico del progetto: quello in cui l'idea prende vita e comincia lentamente a trasformare l'invisibile in presenza.

Every great journey begins with an invisible intuition, a thought still free, still searching for its own form. Before material, before technique, it exists the creative gesture through which the designer shapes new relationships between light, surface, and space. It is the freest and most authentic moment of the project – the one in which an idea comes alive and slowly begins to transform the invisible into presence.



Francesca Lanzavecchia

Ogiva nasce da una riflessione sul dialogo tra materia e tensione, tra trasparenza e massa. Nel suo nome vive un archetipo architettonico antico, l'arco ogivale: una forma capace di trasformare la gravità in slancio. Ho voluto evocare la stessa energia in un sistema di tavoli che fosse insieme struttura e attraversamento, presenza e luce.

Ogiva began as a reflection on tension. Between matter and lightness. Between weight and lift. Its name refers to the pointed arch, an ancient architectural form capable of transforming gravity into upward thrust. I wanted to translate that structural principle into a domestic scale, creating a family of tables that operate simultaneously as structure and passage, presence and light.

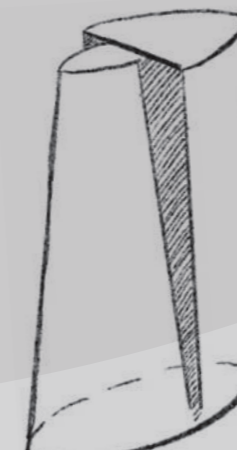
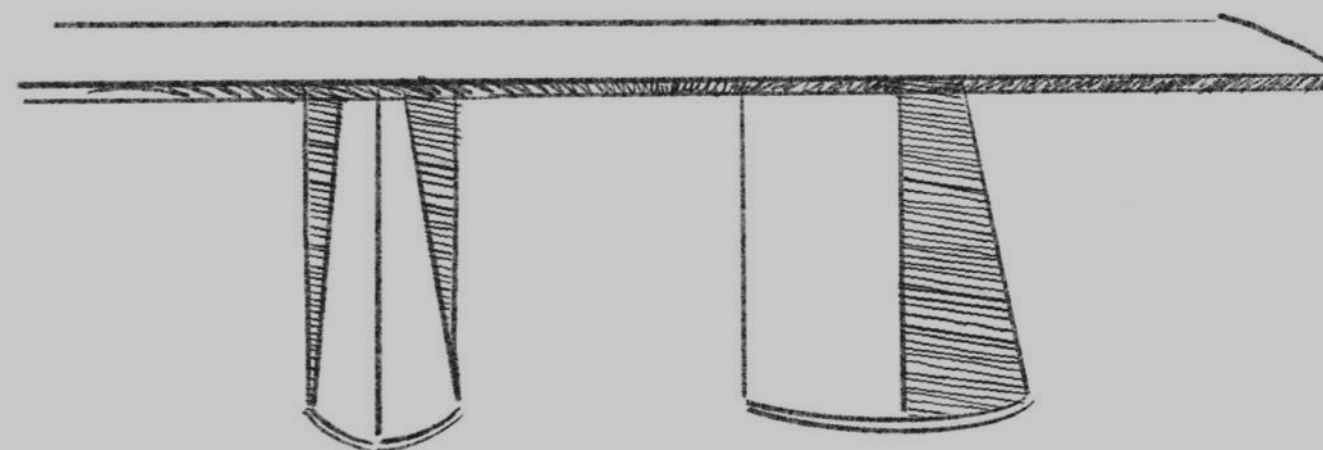
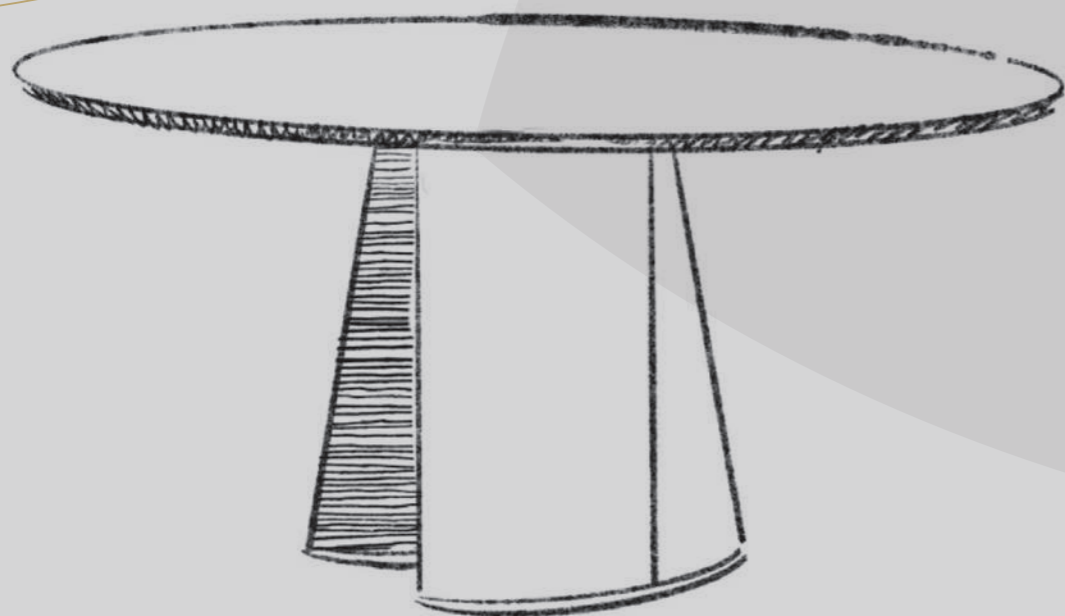

ogiva



Meneghello Paoletti

Trivium nasce dall'incontro di due anime: il vetro, cuore pulsante dell'azienda, sofisticato e luminoso, e il legno, materia viva che dona solidità e carattere.

Trivium emerges from the meeting of two distinct souls: glass, the company's beating heart - refined and luminous - and wood, a living material that lends solidity and character.

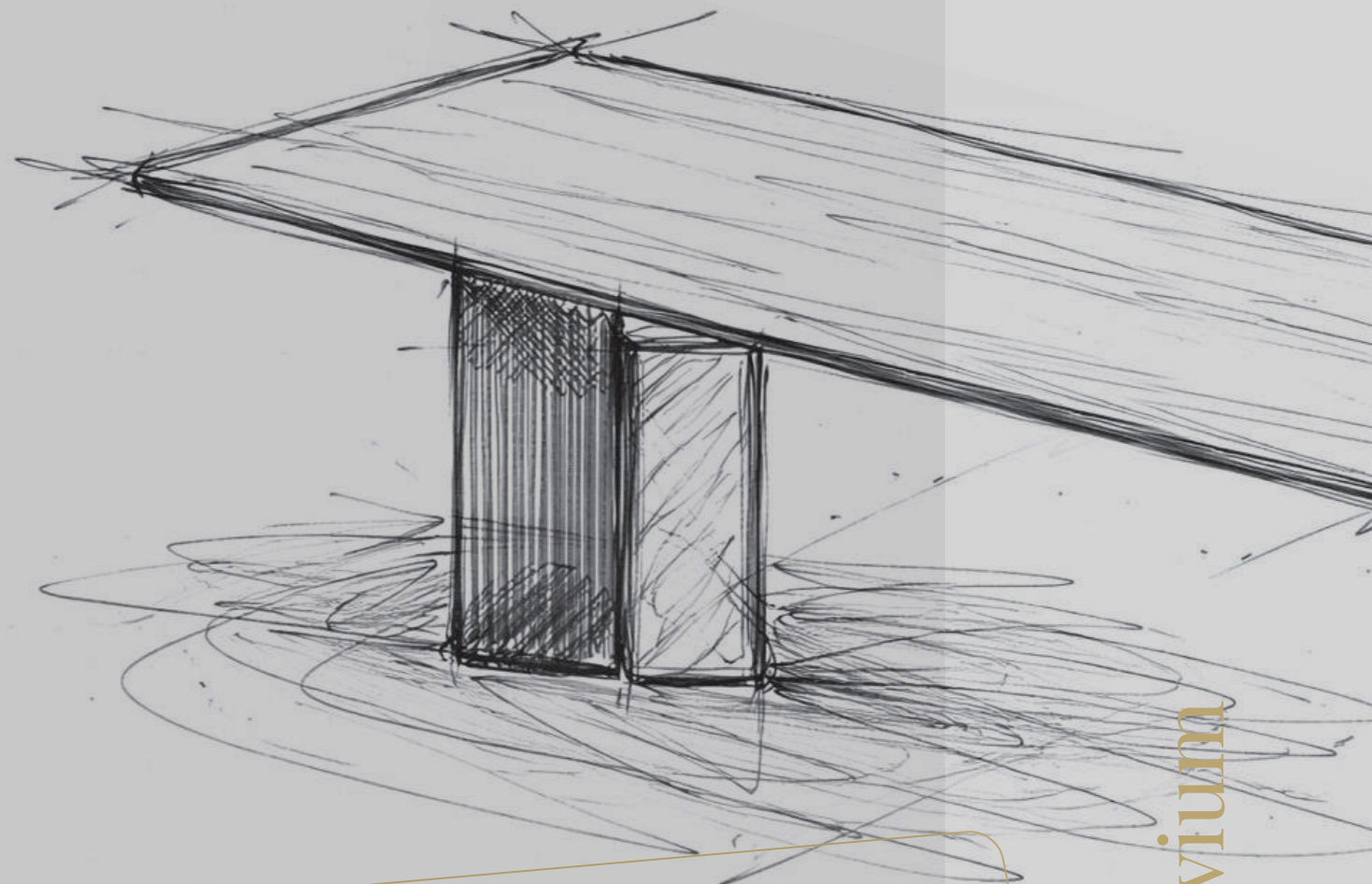
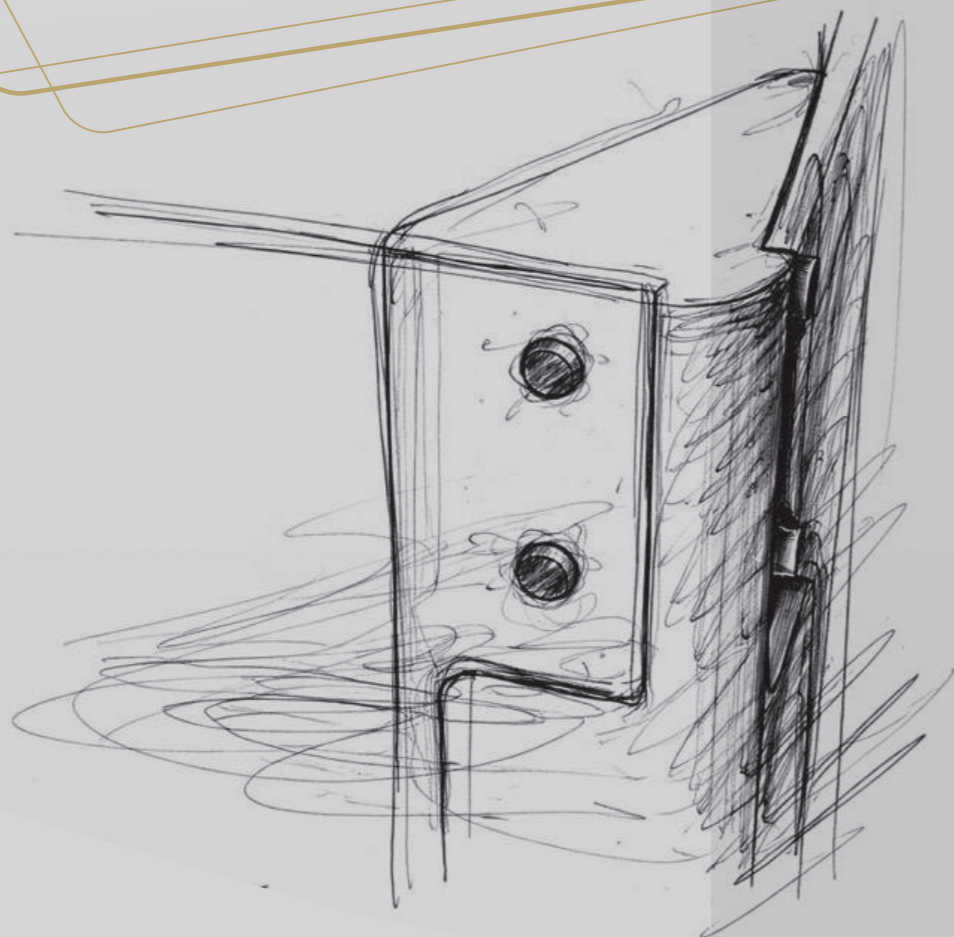

trivium

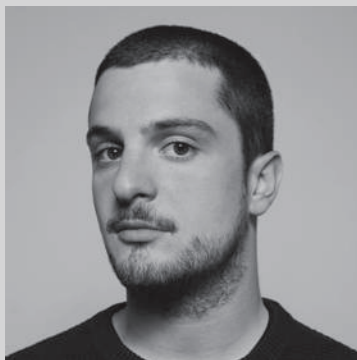

Simone Bonanni

L'obiettivo è stato quello di disegnare una sedia imbottita capace di inserirsi con naturalezza nella varietà degli ambienti Fiam, mantenendo al tempo stesso una connotazione estetica precisa e riconoscibile.

The goal was to design an upholstered chair capable of naturally fitting into the variety of Fiam environments, while maintaining a precise and recognizable aesthetic identity.

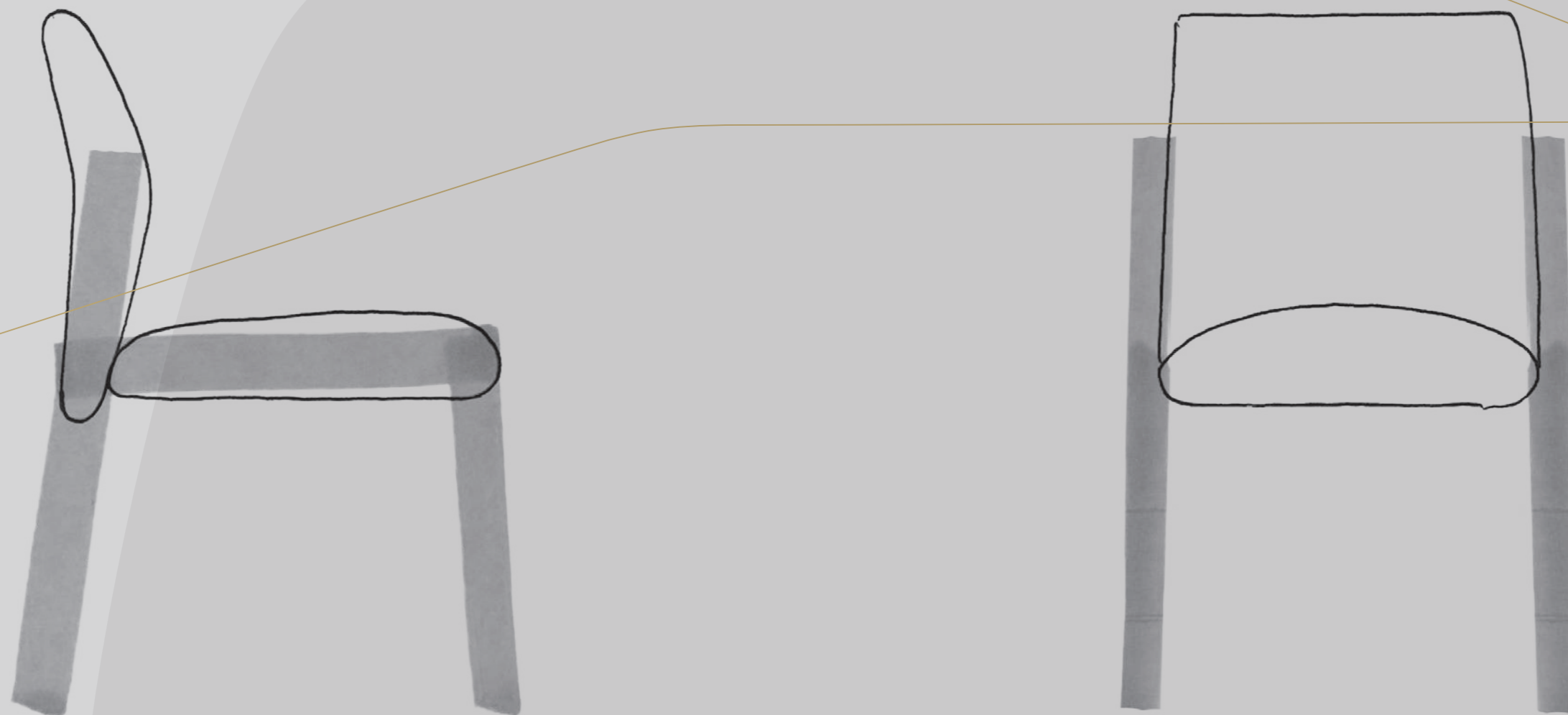

brenta



Controvento

Still è uno specchio che indaga il riflesso come forma, materia ed esperienza. Ispirato alla superficie silenziosa dei laghi alpini ed al paesaggio circostante, il progetto traduce la presenza calma dell'acqua in un gesto scultoreo preciso, in cui l'immobilità diventa una condizione attiva, non uno stato passivo.

Still is a mirror that investigates reflection as form, material, and experience. Inspired by the silent surface of alpine lakes and the surrounding landscape, the project translates the calm presence of water into a precise, sculptural gesture, where stillness becomes an active condition rather than a passive state.

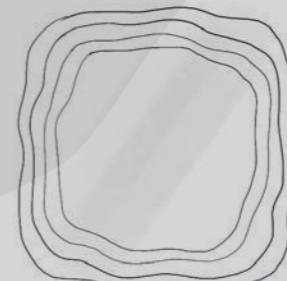
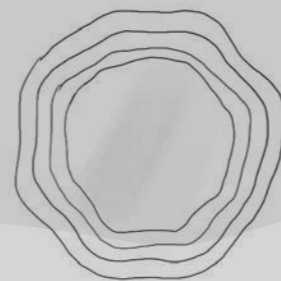
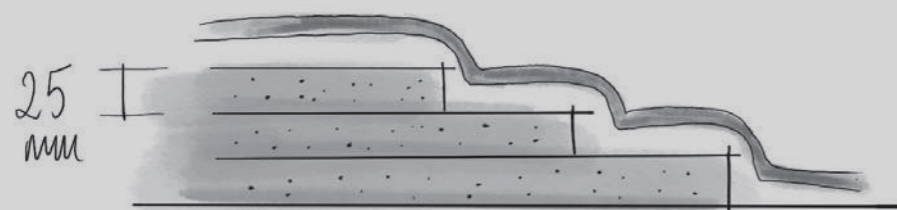
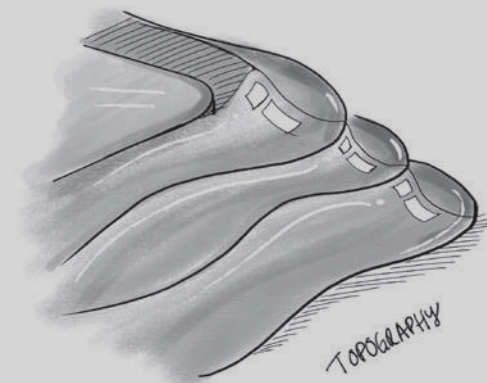
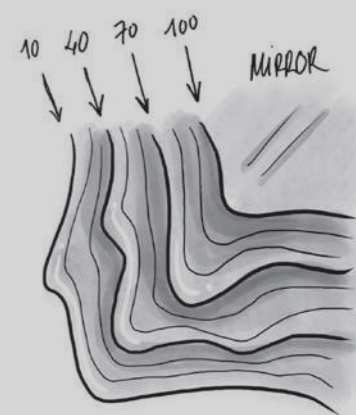



Gupica

Istante trasforma l'idea dell'attimo catturato in un'oggetto di vetro, dove chi si specchia diventa protagonista della propria quotidianità. Un rettangolo riflettente, forma essenziale e pura, accoglie il riflesso senza imporsi, abitando con discrezione lo spazio.

Istante transforms the idea of a captured moment into an object of glass, where those who gaze into it become the protagonists of their everyday lives. A reflecting rectangle, with its essential and pure form, welcomes the reflection without imposing itself, inhabiting the space with subtlety.



oggetto che invita alla contemplazione

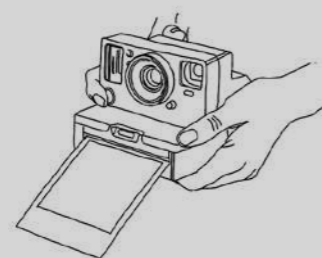

Istante

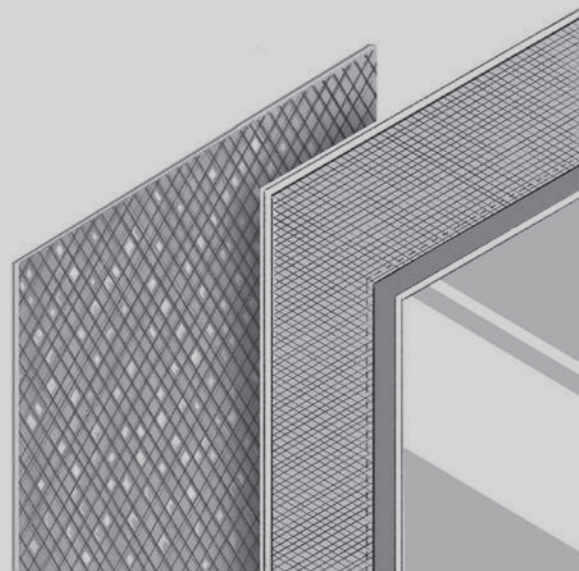

Attimo unico e irripetibile

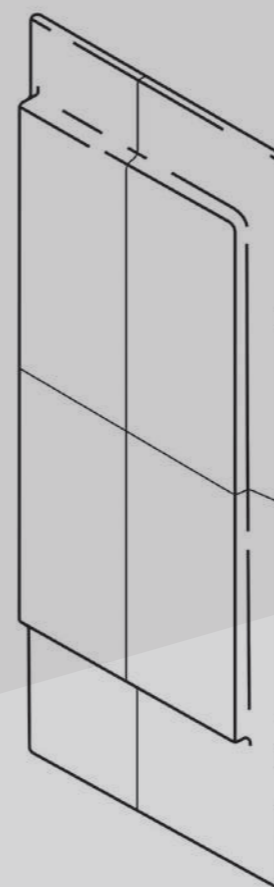
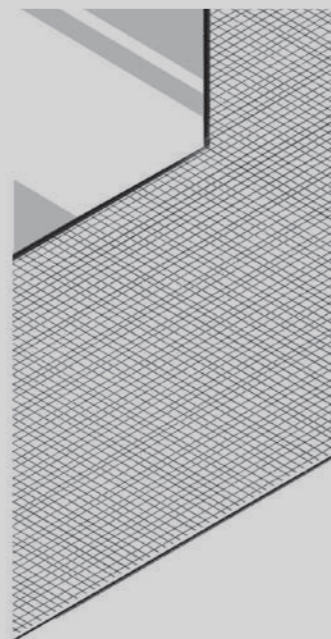

istante



Arik Levy

Nata dalla memoria del cosmo – dalla polvere di stelle, dalla gravità, dall'impatto – la collezione Asteroids esplora l'origine celeste della materia e la sua trasformazione in una quiete assoluta.

Born from the memory of the cosmos – from stardust, gravity, and impact – the Asteroids collection explores the celestial origin of matter and its transformation into pure stillness.

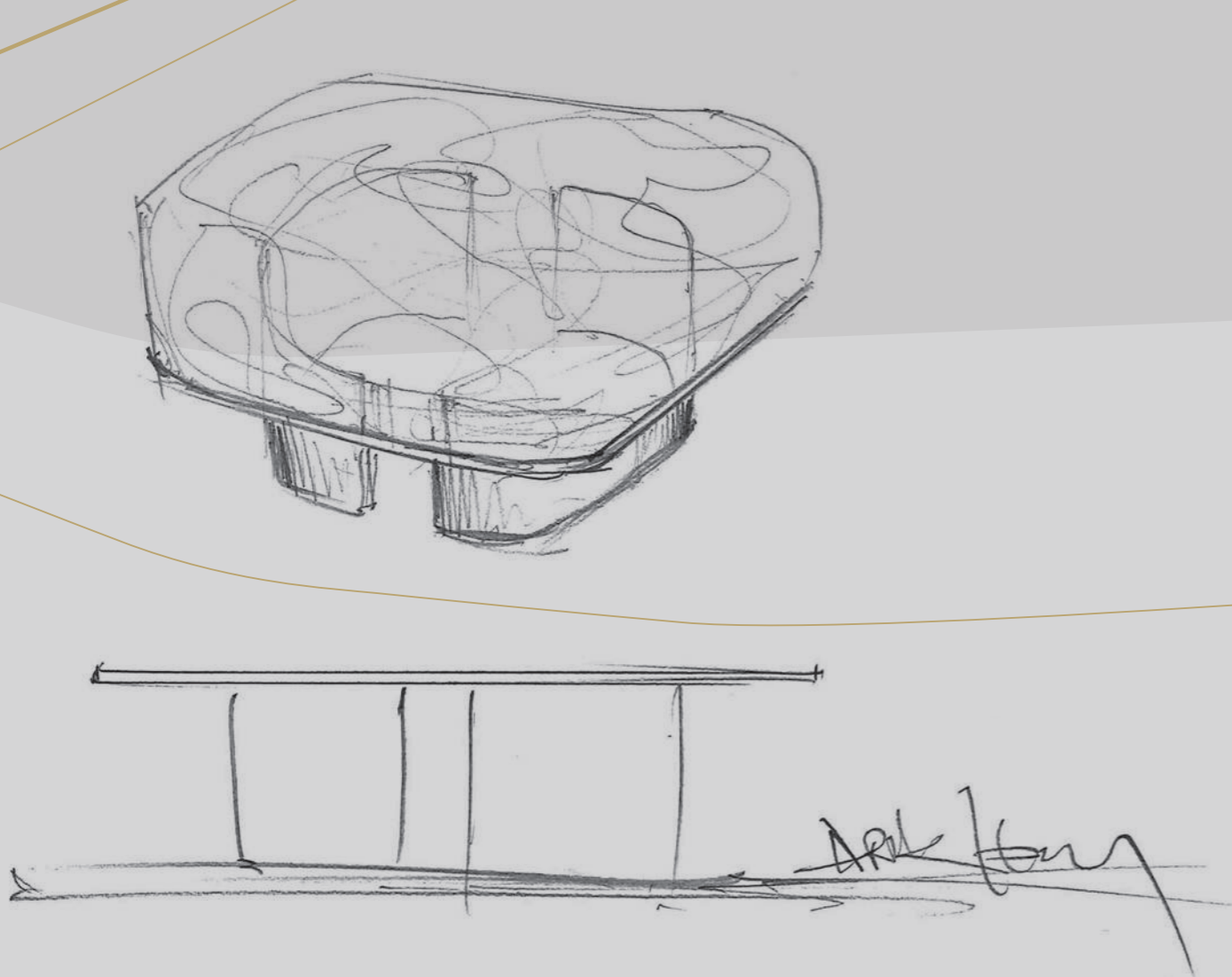

asteroids



Studio Klass

Il sistema di contenitori progettato da Studio Klass per Fiam nasce dalla ricerca di un nuovo equilibrio tra materiali, geometrie e funzionalità. Elemento centrale del progetto è il frame sottile ed essenziale, studiato per alleggerire visivamente la struttura e dare risalto ai materiali.

This cupboard designed by Studio Klass for Fiam stems from the pursuit of a new balance between materials, geometries, and functionality. At the heart of the project lies a slim, essential frame, conceived to visually lighten the structure and enhance the materials.

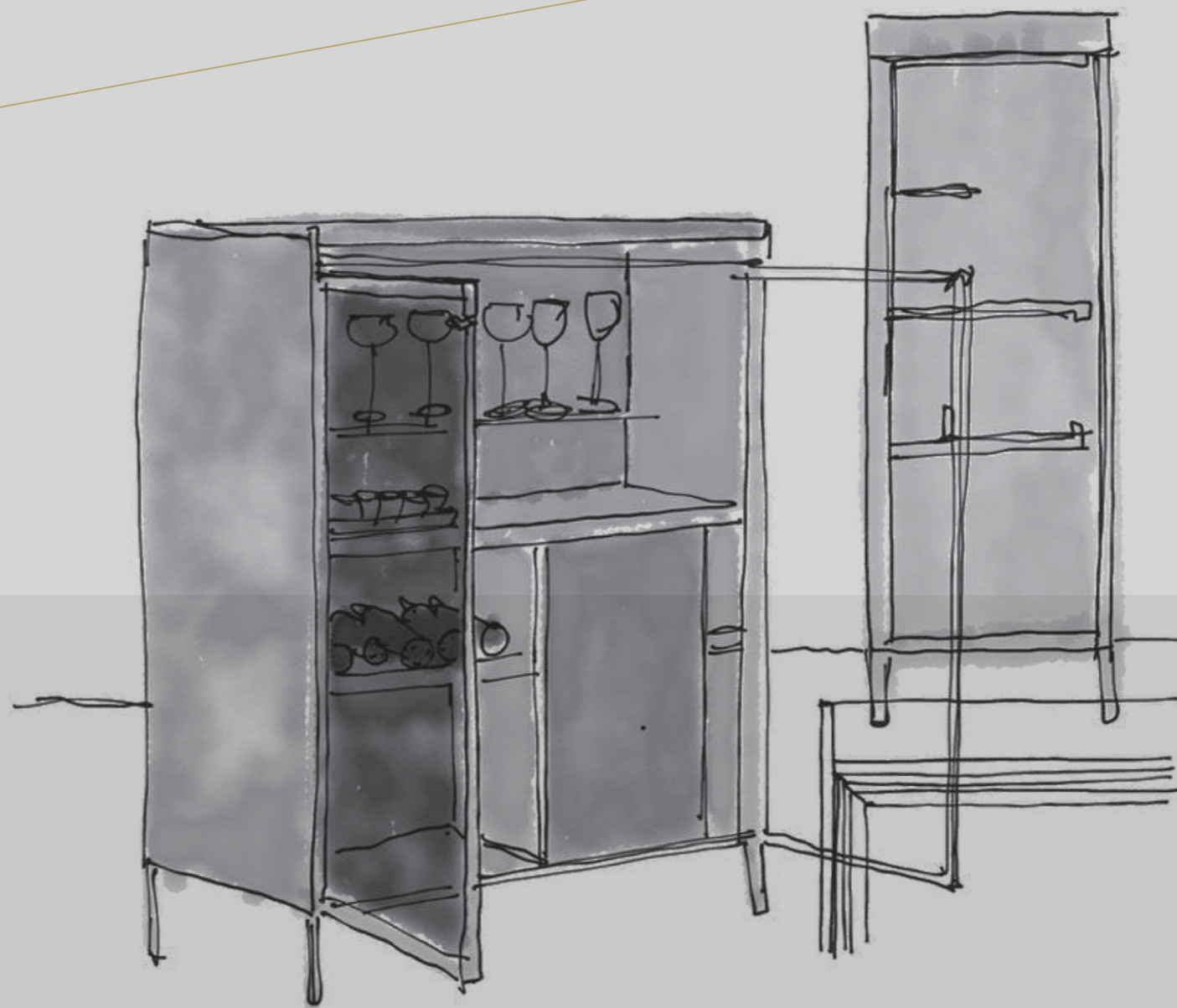
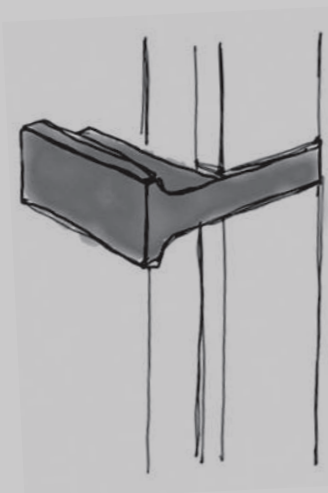
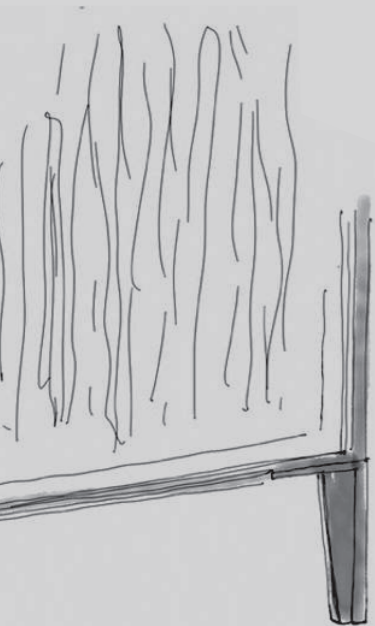

segesta bar



Ceriani Szostak

Onair è una poltrona che bilancia presenza e assenza, volume e leggerezza. Progettata con eleganza garbata e discreta, si integra perfettamente in qualsiasi ambiente, completando lo spazio senza essere invadente.

Onair is an armchair that balances presence and absence, volume and lightness. Designed with refined elegance and discretion, it seamlessly integrates into any setting, completing the space without being intrusive.

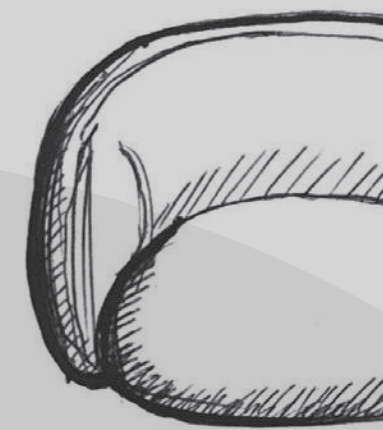
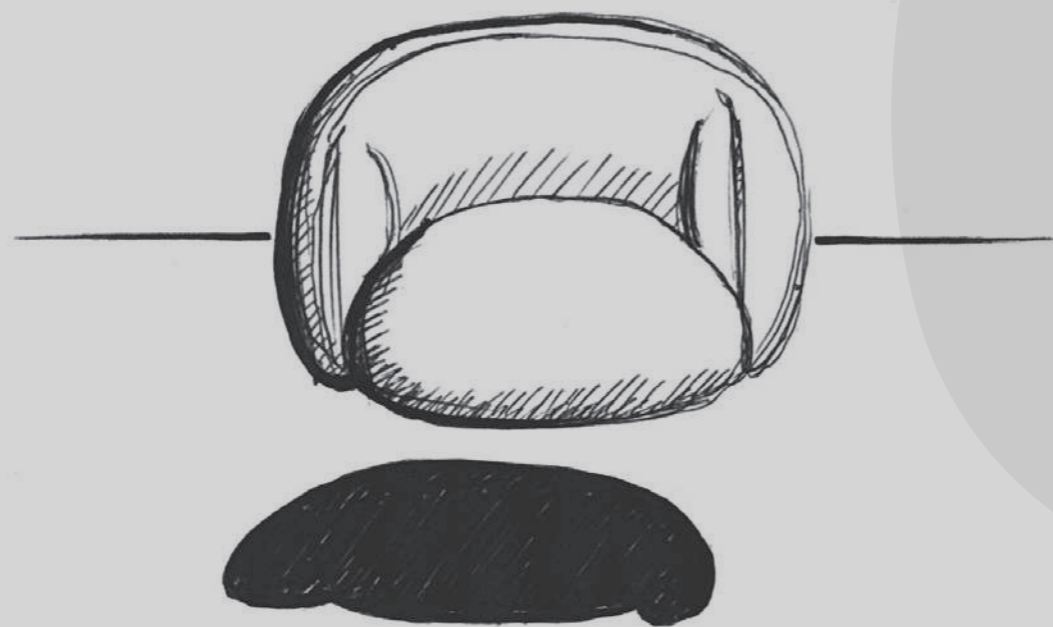

onair

Le nuove collezioni

The new collections

Dall'astrazione del pensiero alla concretezza della forma. Il design di Fiam prende vita nel passaggio cruciale in cui l'idea incontra la maestria esecutiva.

Attraverso un'osmosi perfetta tra la libertà creativa dei designer e la sapienza dei nostri artigiani, il vetro si modella, si trasforma e si compie, superando la dimensione dell'oggetto d'arredo per diventare autentica opera d'arte.

From the abstraction of thought to the concreteness of form. Fiam design comes to life in the crucial passage where an idea meets the mastery of execution.

Through a perfect osmosis between the creative freedom of designers and the wisdom of our artisans, glass is shaped, transformed, and fulfilled - transcending the dimension of a furnishing object to become a true work of art.



Il piano in vetro, cifra identitaria di FIAM, è realizzato in vetrofusione e si offre come una superficie attraversata dalla luce. Non è una trasparenza assoluta, ma una materia vibrante, capace di filtrare e diffondere la luminosità con profondità. La vetrofusione trattiene la luce e la restituisce con morbidezza, lasciando intravedere la struttura metallica sottostante, che affiora e si ritrae a seconda dell'incidenza luminosa e del punto di vista.

È nell'inclinazione e nell'innesto sotto il piano che si costruisce la tensione del progetto. Le gambe, volutamente volumetriche e scolpite, sono presenze plastiche compatte che introducono un contrappunto deciso rispetto alla leggerezza del vetro. Il contrasto tra l'opacità del metallo e la luminosità stratificata del piano non è opposizione, ma dialogo. Ogni gamba muta a seconda del lato da cui la si osserva, restituendo profili differenti e nuovi rapporti tra pieni e vuoti. Camminando intorno al tavolo, l'immagine non è mai statica, ma in continua trasformazione.

The glass top, central to FIAM's material language, is created through glass fusion. It is not neutral transparency, but a crafted surface that filters and modulates light with depth. The fused glass holds luminosity within its body, allowing the metal structure beneath to emerge and recede according to viewpoint and changing light conditions.

The perception shifts as one moves around it. It is in the inclination and in the way the elements meet beneath the top that the project's internal tension takes shape. The legs are volumetric, almost sculptural presences. Their opacity intensifies the luminosity of the glass rather than opposing it. Each angle reveals a different profile, subtly recalibrating balance and weight.

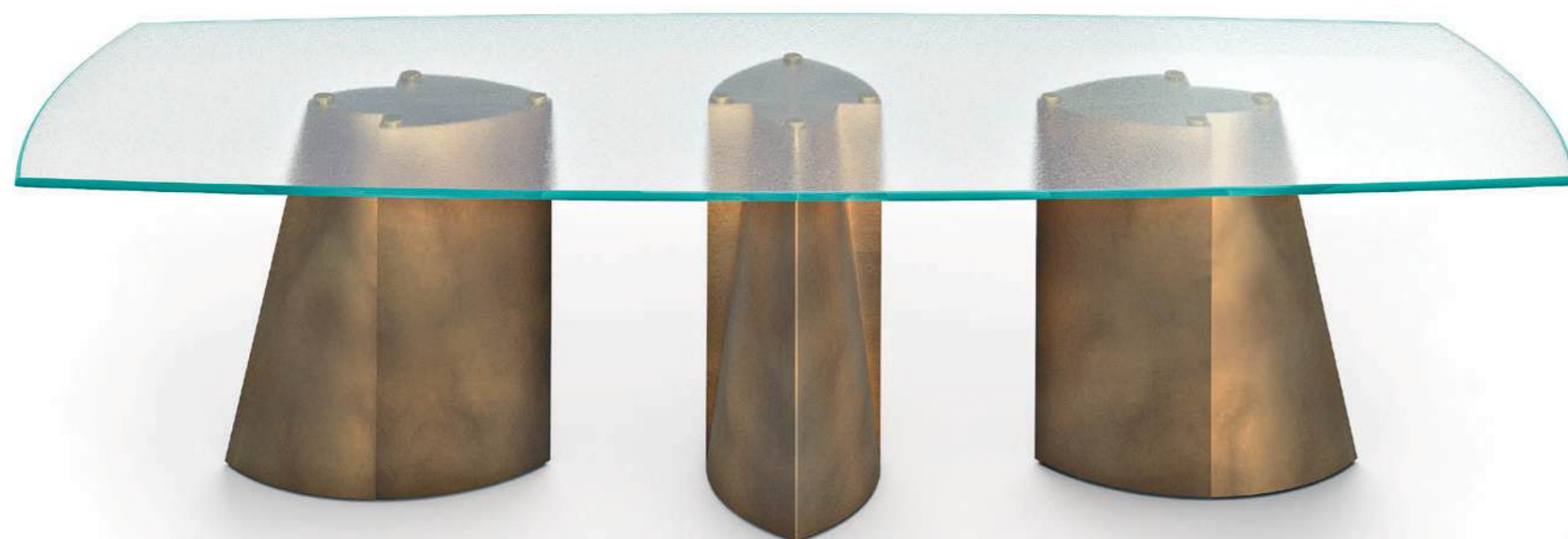

Burnished Brass bases;
Fused glass top.
300 x 118 x H75 cm

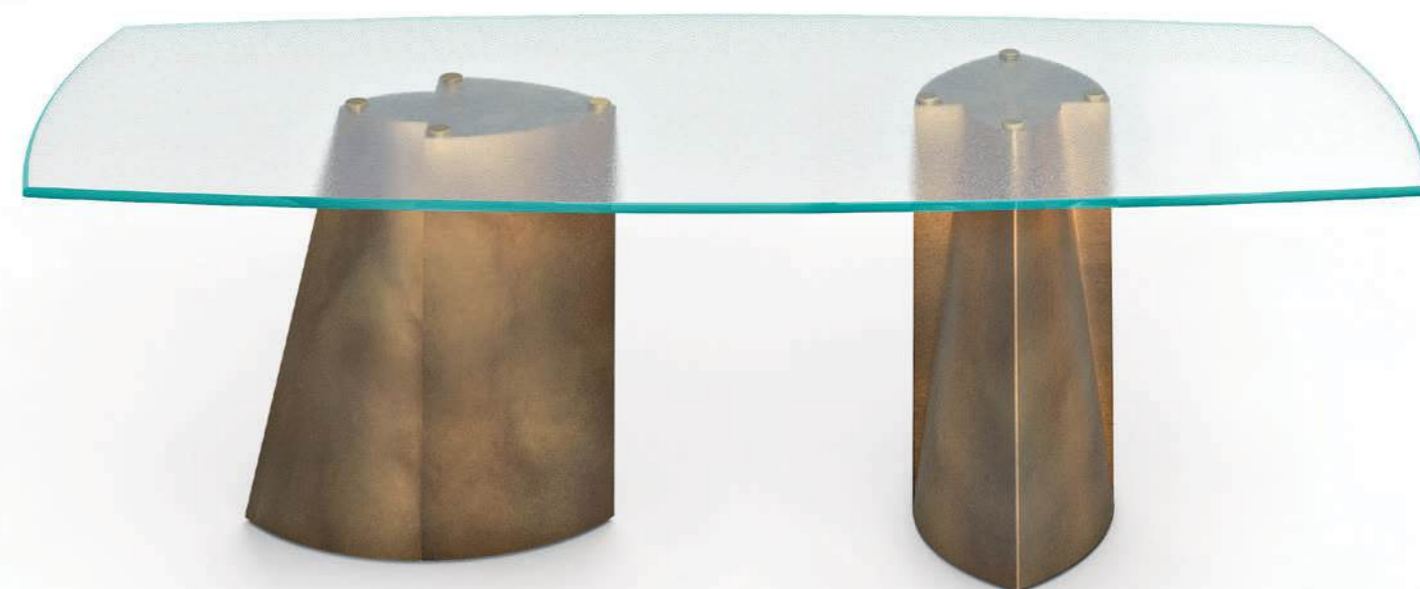

Burnished Brass bases;
Fused glass top.
240 x 110 x H75 cm

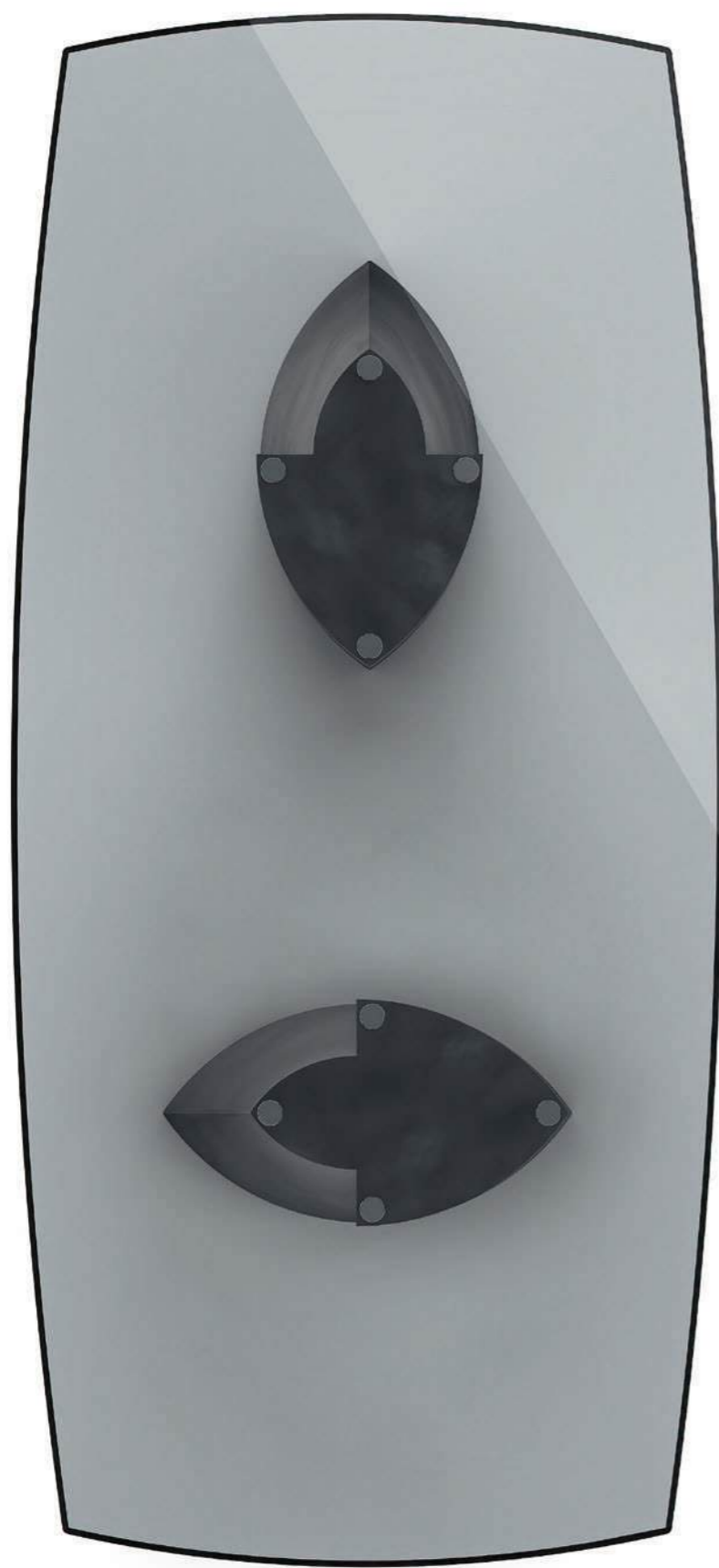

Peltro finish bases;
Layered smoked glass top.
240 x 110 x H75 cm



Metallic Greige lacquered base;
Mystic Brown marble top.
ø180 x H78 cm



Metallic Greige lacquered base;
Layered bronze glass top.
ø180 x H75 cm



Burnished Brass bases;
Calacatta Royal marble top.
300 x 118 x H78 cm

Trivium nasce dall'incontro di due anime: il vetro, cuore pulsante dell'azienda, sofisticato e luminoso, e il legno, materia viva che dona solidità e carattere. Nei cavalletti triangolari, costruiti come piccole architetture domestiche, i materiali non si sovrappongono ma si cercano, in equilibrio dinamico.

È un progetto che racconta un abbraccio: tra trasparenza e materia, tra visione e radicamento.

Trivium emerges from the meeting of two distinct souls: glass, the company's beating heart - refined and luminous -and wood, a living material that lends solidity and character. In the triangular trestles, shaped as small domestic architectures, the materials do not overlap but seek one another, held in dynamic balance.

It is a project that speaks of an embrace: between transparency and substance, between vision and grounding.

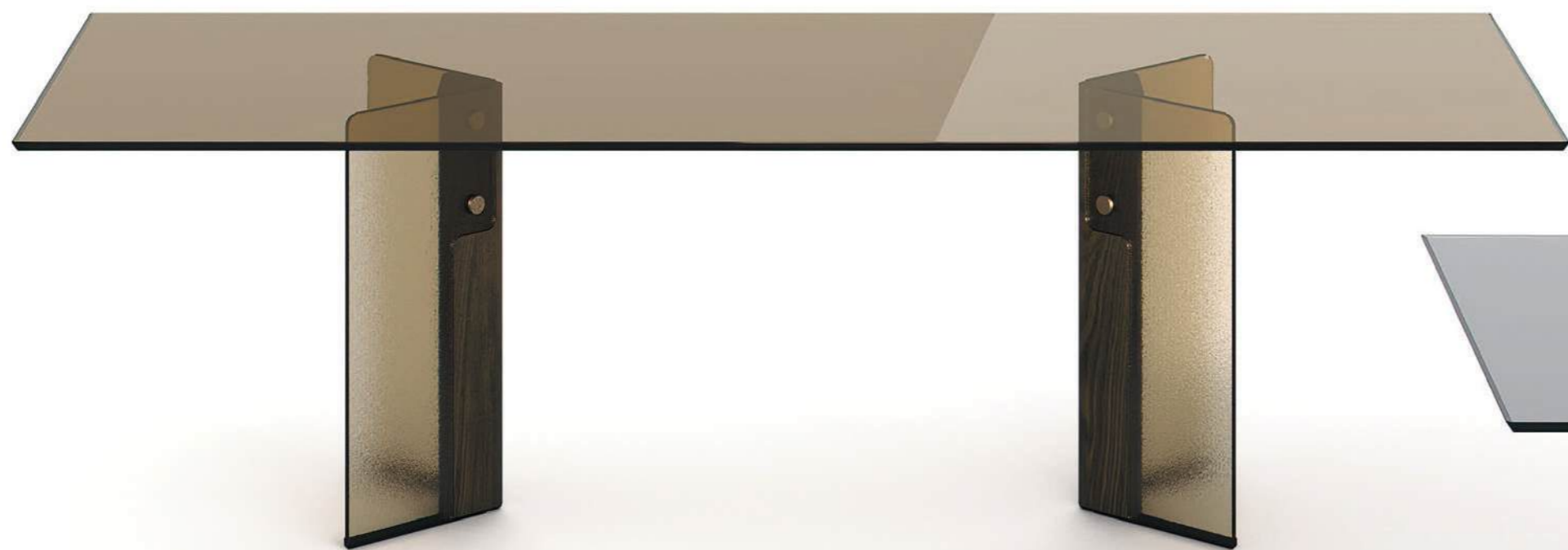

Fused bronze glass and Tobacco finish solid wood bases;
Layered bronze glass top.
260 x 110 x H75 cm



Fused smoked glass and Black finish solid wood bases;
Layered smoked glass top.
260 x 110 x H75 cm



Fused smoked glass and Black finish solid wood bases;
Canaletto walnut, Black finish top.
260 x 110 x H78 cm



Fused bronze glass and Tobacco finish solid wood bases;
Canaletto walnut, Tobacco finish top.
260 x 110 x H78 cm

In pieno spirito Fiam, dove ogni pezzo nasce da un ragionamento progettuale autonomo e dialoga con lo spazio per contrappunto e non per assonanza, la sedia Brenta si fonda su un segno grafico chiaro: un fianco sagomato in legno massello che unisce seduta e schienale in pelle o in tessuto, diventando struttura portante. Un gesto progettuale netto ed essenziale che definisce una seduta capace di farsi riconoscere rimanendo discreta, in un perfetto equilibrio tra rigore e identità.

In true Fiam spirit, where each piece stems from an autonomous design reasoning and engages with the space through counterpoint rather than formal resemblance, the Brenta chair is built around a clear graphic gesture: a shaped solid wood side element that connects the seat and backrest in leather or fabric, becoming the structural core. A sharp and essential design move that defines a chair able to stand out while remaining discreet, achieving a perfect balance between rigor and identity.



Black finish solid wood structure;
Silky leather upholstery, Pepe color.

brenta
Simone Bonanni



Tobacco finish solid wood structure;
Nubuck upholstery, Dark Brown color.



Tobacco finish solid wood structure;
Silky leather upholstery, Fondente color.



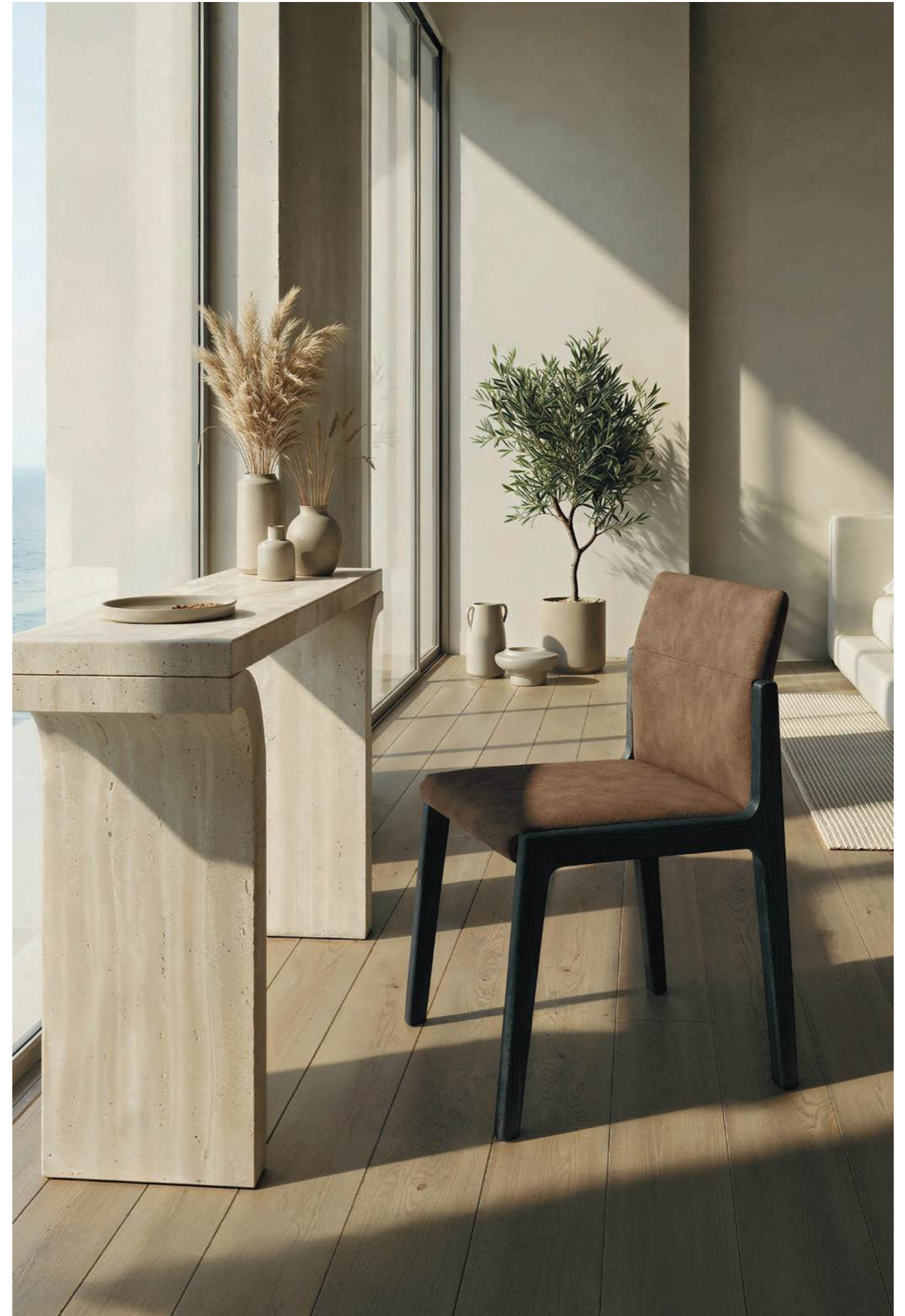

Black finish solid wood structure;
Nubuck upholstery, Chestnut Brown color.

Al centro del progetto c'è il vetro, materia per sua natura legata alla trasformazione. Portato a uno stato morbido e modellato attraverso processi controllati, ritorna alla solidità conservando la memoria del movimento. Questa dualità ne influenza il design: una superficie che appare stabile ma suggerisce il fluire, catturando l'istante in cui il liquido diventa forma.

Lo specchio si pone come interfaccia tra oggetto e ambiente. Più che riflettere, riformula lo spazio, frammentando e ricomponendo il paesaggio circostante attraverso lievi distorsioni e slittamenti percettivi. Luce, contesto e posizione dell'osservatore ridefiniscono continuamente l'oggetto, trasformando il riflesso in un evento in costante evoluzione.

At the center of the project is glass, a material defined by transformation. Heated to a soft state and shaped through controlled processes, it returns to solidity while retaining the memory of movement. This duality informs the design language: a surface that appears stable yet suggests flow, capturing the moment where liquid becomes form.

The mirror operates as an interface between object and environment. Rather than simply reflecting, it reframes space, fragmenting and recomposing the surrounding landscape through subtle distortions and shifts in perception. Light, context, and the viewer's position continuously redefine the object, making reflection an evolving event.



Rectangular mirror,
standard finish.
130 x 10 x 208 cm



Rectangular mirror,
smoked finish frame.
130 x 10 x 208 cm





Rectangular mirror,
bronze finish frame.
130 x 10 x 208 cm



Round mirror,
bronze finish frame.
ø130 x 10 cm



Rectangular mirror,
standard finish.
130 x 10 x 208 cm

La cornice, con la sua superficie tridimensionale e materica, valorizza il vetro attraverso una micro-texture creata ad hoc, che amplifica la densità tattile del materiale e invita lo sguardo a perdersi nei dettagli. Istante è uno specchio che invita alla contemplazione, diventando testimone dell'identità, del tempo e dello spazio che abitiamo. Un'architettura dello sguardo, che raccoglie tracce della nostra presenza restituendole come un ricordo appena emerso. Come una fotografia istantanea, lo specchio restituisce il presente e al tempo stesso ne suggerisce la memoria, configurandosi come un intreccio sottile di identità, tempo e spazio che abitiamo. La collezione si sviluppa in formati differenti, ciascuno pensato per attivare relazioni specifiche con lo spazio e con chi li osserva.

The frame, with its three-dimensional, tactile surface, enhances the glass through a bespoke micro-texture that amplifies the material's tactile depth and invites the eye to linger on the details.

Istante is a mirror that encourages contemplation, becoming a witness to identity, time, and the space we inhabit. An architecture of the gaze, it collects traces of our presence and returns them as a memory just surfaced. Like an instant photograph, the mirror reflects the present while suggesting memory, forming a delicate interplay of identity, time, and space.

The collection is available in different sizes, each designed to engage specific relationships with the space and with those who observe it.

FIAM
Made in Italy - B-BF

istante
Gupica



Smoked glass frame.
54 x 3 x 86 cm
72 x 3 x 86 cm



Bronze glass frame.
Green glass frame.
68 x 3 x 180 cm



Bronze glass frame.
108 x 3 x 130 cm



Ogni tavolino afferma una presenza fisica forte, innegabile. Il piano si posa su due elementi scultorei in vetro, dando vita a un dialogo tra equilibrio e gravità.

Queste forme verticali non sono semplici sostegni, ma ancore monolitiche nello spazio, capaci di mantenere la superficie in uno stato di silenziosa armonia. La luce scorre sui volumi solidi, si diffonde lungo i bordi e rivela sottili variazioni di texture e riflesso.

Il tavolino appare come radicato nel suo ambiente, assorbendo e trattenendo lo spazio circostante. A seconda dell'ora del giorno e dell'angolazione dello sguardo, cattura l'attenzione mutando tra ombra e forma, sempre intensamente presente.

La collezione Asteroids parla di origine e trasformazione – di solido che si fa liquido, di liquido che si fa forma, di forma che si fa sostanza.

È un'esplorazione di geometrie essenziali e densità materica, dove funzione e scultura convergono in un unico silenzioso gesto.

Each table asserts a bold, undeniable physical weight. The tabletop rests on two sculptural glass elements, creating a dialogue between balance and gravity.

These vertical forms act not only as supports but as monolithic spatial anchors, holding the surface in a state of quiet equilibrium. Light plays across the solid volumes, diffuses along the edges, and reveals subtle variations in surface texture and reflection.

The table grounds its environment, absorbing and anchoring the space around it. Depending on the time of day and the angle of view, it commands attention, shifting in shadow and form, always profoundly present.

The Asteroids collection speaks of origin and transformation – of earth becoming liquid, of liquid becoming form, of form becoming substance.

It is an exploration of essential geometry and material density, where function and sculpture converge in a single, quiet gesture.

asteroids
Arik Levy



Fused glass base and top,
Brilliant Mud back-painted.
109 x 114 x H30 cm

Fused glass base, Brilliant Mud
back-painted; Mystic Brown marble top.
109 x 114 x H36 cm



Mystic Brown marble top.
109 x 114 x H36 cm



Fused glass base and top,
Brilliant Brown back-painted.
109 x 114 x H30 cm

Fused glass base and top,
Copper Brown back-painted.
109 x 114 x H35 cm



Fused glass base and top,
Brilliant Mud back-painted.
109 x 114 x H30 cm

Fused glass base, Brilliant Mud back-
painted; Calacatta Royal marble top.
109 x 114 x H36 cm

Elemento centrale del progetto è il frame sottile ed essenziale, studiato per alleggerire visivamente la struttura e dare risalto ai materiali. Questa cornice architettonica racchiude le superfici con leggerezza, creando un raffinato gioco di volumi sospesi e valorizzando il contrasto tra la solidità del top e la trasparenza delle ante.

L'armonia tra pieni e vuoti, unita alla pulizia formale, conferisce al sistema un'eleganza discreta e una leggerezza visiva che lo rendono adatto a tutti gli ambienti contemporanei.

At the heart of the project lies a slim, essential frame, conceived to visually lighten the structure and enhance the materials. This architectural framework encloses the surfaces with a sense of lightness, creating a refined interplay of suspended volumes and highlighting the contrast between the solidity of the top and the transparency of the doors.

The harmony between solid and void, combined with a clean, formal aesthetic, conveys to the system a discreet elegance and visual lightness, making it suitable for all contemporary interiors.



segesta bar
Studio Klass



Moka lacquered external structure; bronze glass doors;
Mystic Brown marble top.
115 x 41 x H146 cm - VERSION WITH DRAWERS.



Moka lacquered external structure; bronze glass doors;
Mystic Brown marble top.
115 x 41 x H146 cm - VERSION WITH REFRIGERATOR.



Vulcano Grey lacquered external structure;
smoked glass doors;
Carnico Grey marble top.
115 x 41 x H146 cm - VERSION WITH DRAWERS

Sulla poltroncina Onair, le gambe sono sostituite dal vetro curvo caratteristico di Fiam Italia, creando una separazione visiva tra la seduta e il pavimento. Questo aumenta la sensazione di galleggiamento, come se la poltrona fosse sospesa in aria. Questa sottile interazione di forma solida e trasparenza conferisce a ONAIR una presenza che è allo stesso tempo definita e sfuggente, tangibile ma eterea, dove il comfort incontra l'illusione di leggerezza.

Instead of traditional legs, ONAIR features FIAM Italia's signature curved glass, creating a visual separation between the seat and the floor that enhances the sense of floating, as if the armchair was suspended in mid-air. This subtle interplay of solid form and transparency gives ONAIR a presence that is both defined and elusive, tangible yet ethereal, where comfort meets the illusion of weightlessness.



Curved glass base;
Teddy Bear fabric upholstery,
01/2 Sabbia color.
80 x 62 x H65 cm



Curved bronze glass base;
Nubuck upholstery, Chestnut Brown color.
80 x 62 x H 65 cm

Dialoghi con lo spazio

Dialogues with space

Un'opera di design non è mai isolata, ma vive nella relazione con ciò che la circonda.

Collocati tra le storiche mura della Villa, i nuovi elementi intrecciano una conversazione silenziosa ma potente con l'ambiente: un ponte temporale in cui il saper fare di ieri accoglie e amplifica la visione di domani. Il vetro diventa così uno specchio fluido, capace di far dialogare la luce, la memoria e il futuro dello spazio abitato.

A work of design is never isolated - it lives in relationship with all that surrounds it.

Placed among the historic walls of the Villa, the new pieces weave a silent yet powerful conversation with their environment: a temporal bridge in which yesterday's craftsmanship welcomes and amplifies the vision of tomorrow. Glass becomes, in this way, a fluid mirror - able to bring into dialogue light, memory, and the future of inhabited space.



ogiva

Francesca Lanzavecchia





trivium
Meneghello Paoletti



brenta

Simone Bonanni



still
Controvento





istante

Gupica

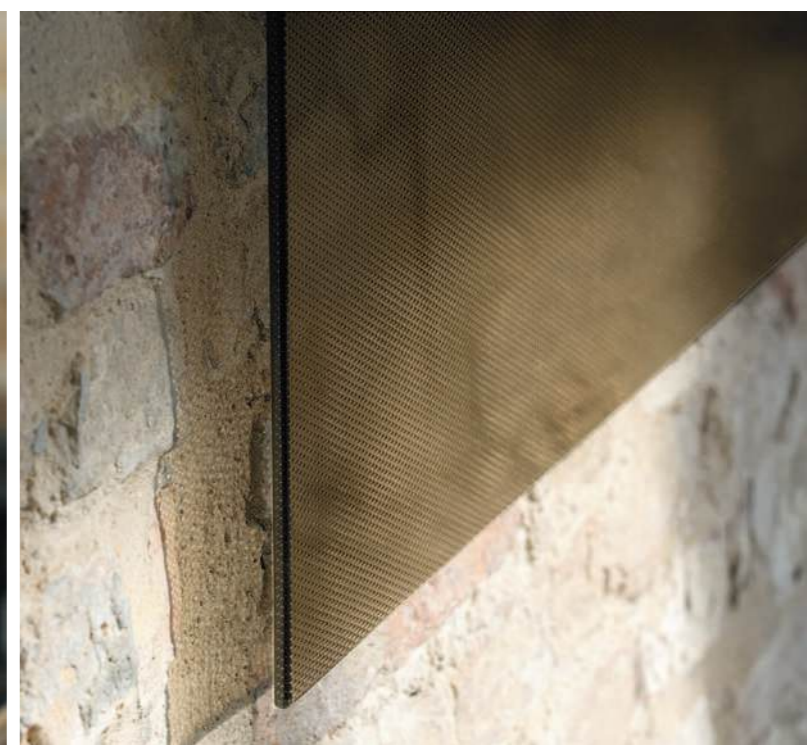



asteroids

Arik Levy

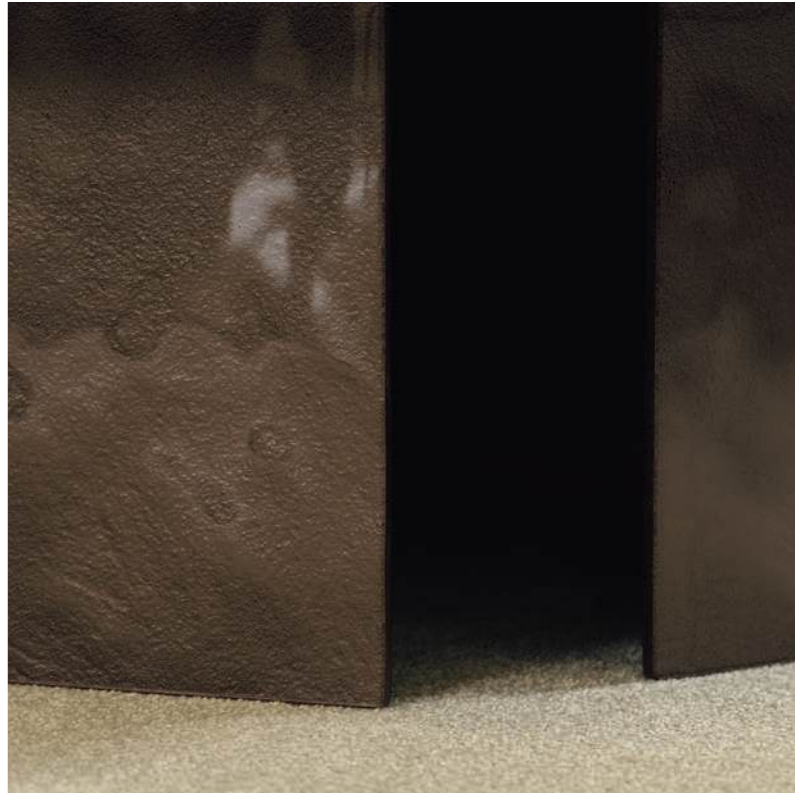

segesta bar

Studio Klass

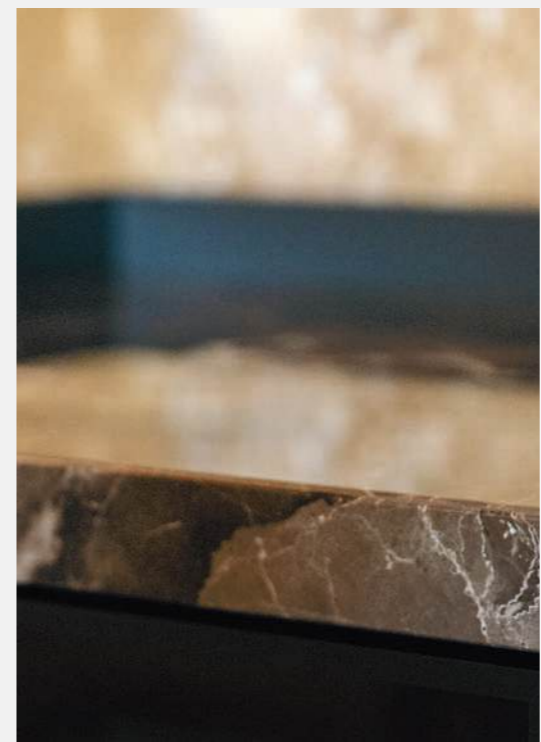

onair

Ceriani Szostak





Fiam Design Day - 2026

Fiam Design Journey è stato molto più di un appuntamento: è stato un viaggio condiviso nel cuore dell'innovazione e della bellezza. Idee in movimento, voci autorevoli del design e frammenti di un'esperienza collettiva che celebra la cultura del progetto e la straordinaria capacità di plasmare il futuro, un dettaglio alla volta.

Fiam Design Journey was so much more than an event: it was a shared journey into the heart of innovation and beauty. Ideas in motion, authoritative voices of design, and fragments of a collective experience that celebrates the design culture and the extraordinary capacity to shape the future, one detail at a time.





Schede tecniche

Technical data

ogiva

Francesca Lanzavecchia

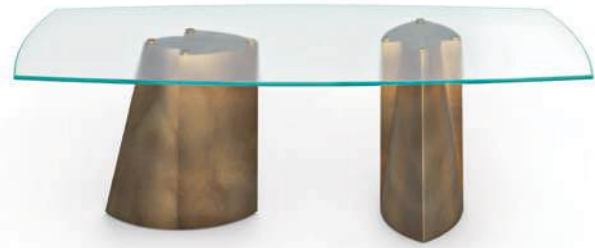

Tavolo con basi in metallo, disponibili verniciate con tinte metallizzate, spatolate in Ecomalta, oppure finite con finiture metalliche premium. Piano sagomato con forma "a botte" in vetro da 15 mm fuso a gran fuoco e temperato, disponibile trasparente o retroverniciato con tinte metallizzate. Il piano è disponibile anche in vetro standard o extralight da 15 mm temperato, oppure in vetro bronzo o fumé da 16 mm stratificato e bisellato. Piano disponibile anche in marmo spessore 20 mm.

Table with metal bases, available laquered with metallic colours, or hand-finished with Ecomalta, or with premium metal finishes. Top made of 15 mm "barrel" shaped glass, fused and tempered, available transparent or back-painted with metallic colours. The top is available also in 15 mm tempered standard or extralight glass, or in 16 mm bronze or smoked glass, layered and bevelled. The top is available also in marble, 20 mm thick.

Base in metallo verniciato Lacquered metal base

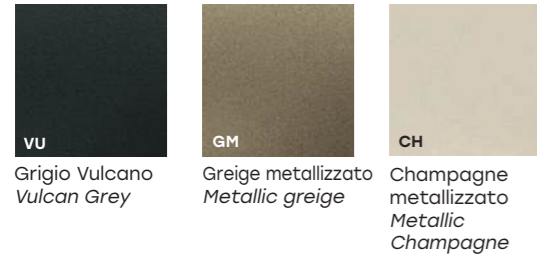

Base in metallo spatolata in Ecomalta® Ecomalta® hand-finished metal base



Base in metallo finitura Premium Premium finish metal base



Piano in vetro temperato _ Tempered glass top



Piano in vetro stratificato _ Layered glass top



Piano in vetro fuso _ Fused glass top



Piano in marmo _ Marble top

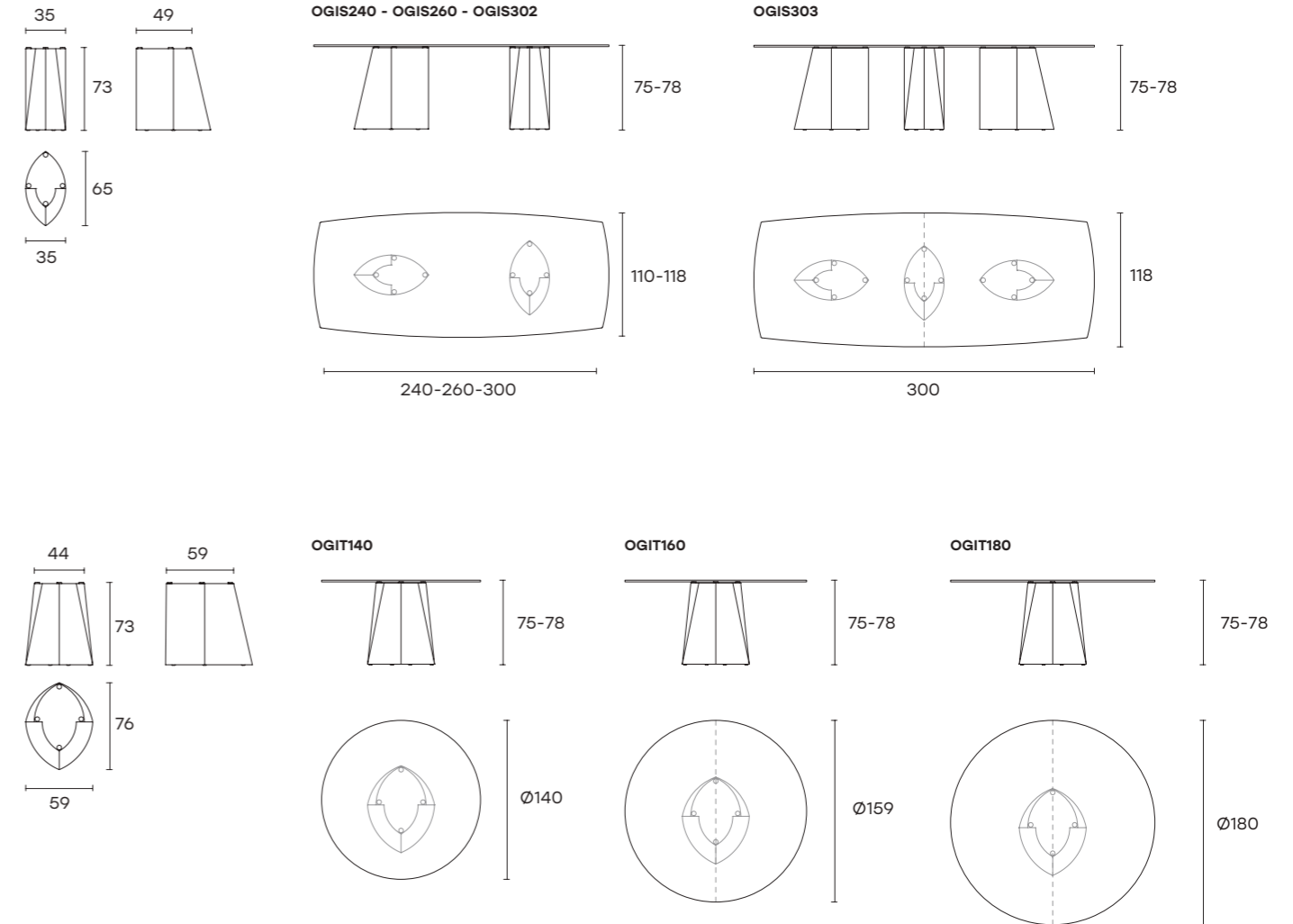
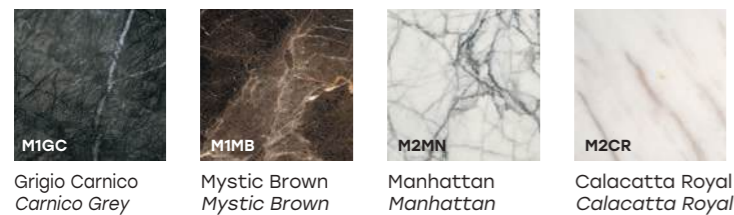

Sagomato/Shaped

L 240 x P 110 x H 75 cm
L 94 1/2" x W 43 5/16" H 29 1/2"

L 260 x P 110 x H 75 cm
L 102 3/8" x W 43 5/16" H 29 1/2"

L 300 x P 118 x H 75 cm
L 78 3/4" x W 46 7/16" H 29 1/2"

Tondo/Round

Ø 140 x H 75 cm
Ø 55 1/8" x H 29 1/2"

Ø 159 x H 75 cm
Ø 62 5/8" x H 29 1/2"

Ø 180 x H 75 cm
Ø 70 7/8" x H 29 1/2"

trivium

Meneghello Paoletti



Tavolo con basi in legno massello e vetro fuso a gran fuoco, disponibili in diverse finiture. Piano in vetro da 15 mm fuso a gran fuoco e temperato, disponibile trasparente o retroverniciato con tinte metallizzate. Il piano è disponibile anche in vetro standard o extralight da 15 mm temperato, oppure in vetro bronzo o fumé da 16 mm stratificato e bisellato. Piano disponibile anche in legno impiallacciato spessore 40 mm.

Table with bases made of solid wood and fused glass, available in various finishes. Top made of 15 mm fused and tempered glass, available transparent or back-painted with metallic colours. The top is available also in 15 mm tempered standard or extralight glass, or in 16 mm bronze or smoked glass, layered and bevelled. The top is available also in veneered wood, 40 mm thick.

Base - Parte in legno massello
Base - Solid wood part

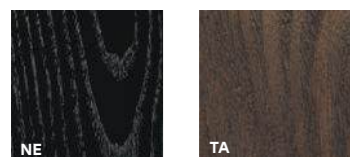

NE
Nero
Black

TA
Tabacco
Tobacco

Piano in legno _ Wood top

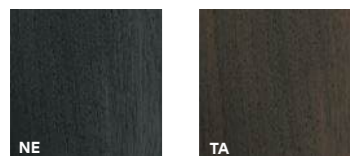

NE
Noce Canaletto
tinto Nero
Canaletto walnut,
Black finish

TA
Noce Canaletto
tinto Tabacco
Canaletto walnut,
Tobacco finish

Piano in vetro fuso _ Fused glass top

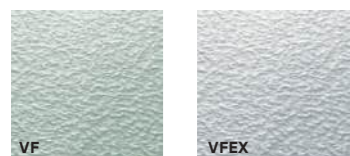

VF
Standard
Standard

VFEX
Extralight
Extralight

Piano in vetro fuso retroverniciato _ Fused and back-painted glass top



VF-NB
Retroverniciato
Grigio Antracite
Anthracite Grey
back-painted

VF-AN
Retroverniciato
Grigio Antracite
Anthracite Grey
back-painted

VF-MK
Retroverniciato
Moka
Moka
back-painted

VF-MB
Retroverniciato
Marrone Brillante
Brilliant Brown
back-painted

VF-TB
Retroverniciato
Terra Brillante
Brilliant Mud
back-painted

VF-BL
Retroverniciato
Blu Notte
Night Blue
back-painted

Base - Parte in vetro fuso
Base - Fused glass part



VF
Standard
Standard

VFEX
Extralight
Extralight

VFGR
Fumé
Smoked

VFBR
Bronzo
Bronze

Piano in vetro temperato
Tempered glass top



SD
Standard
Standard

EX
Extralight
Extralight

Piano in vetro stratificato
Layered glass top

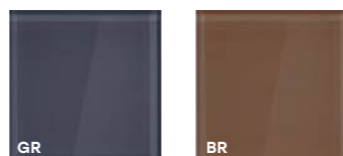

GR
Fumé
Smoked

BR
Bronzo
Bronze

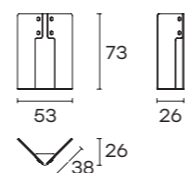

TRIR200

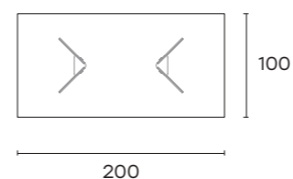
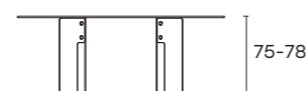

TRIR240 - TRIR260

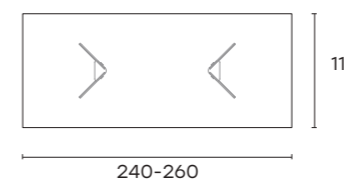
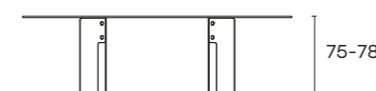

TRIR302 (only with wood top or back-painted glass top)

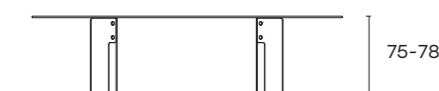

TRIR304

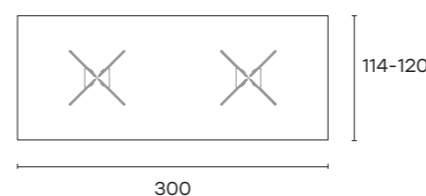

TRIR360 (only with wood top or layered glass top)

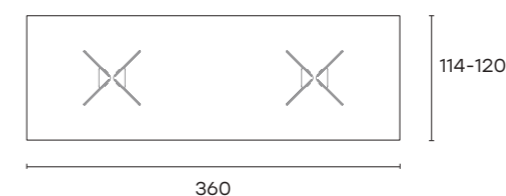
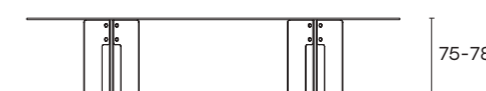

TRIT140

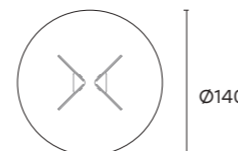
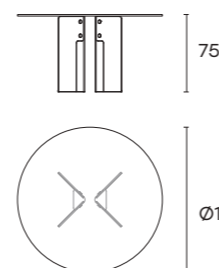

TRIT160

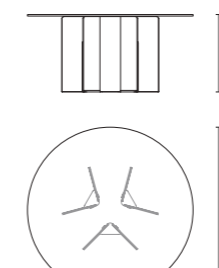

TRIT180

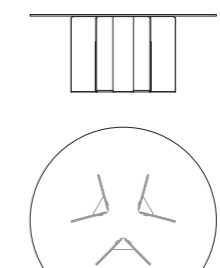

PARTICOLARE PIANO IN LEGNO
WOOD TOP DETAIL

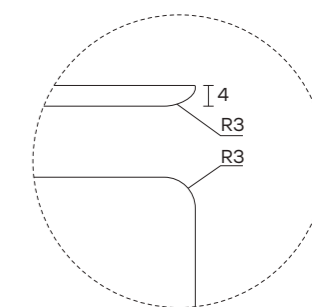

Rettangolare/Rectangular

L 200 x P 100 x H 75 cm
78 3/4" x W 39 3/8" H 29 1/2"

L 240 x P 110 x H 75 cm
94 1/2" x W 43 5/16" H 29 1/2"

L 260 x P 110 x H 75 cm
102 3/8" x W 43 5/16" H 29 1/2"

Tondo/Round

Ø 140 x H 75 cm
Ø 55 1/8" x H 29 1/2"

Ø 159 x H 75 cm
Ø 62 5/8" x H 29 1/2"

Ø 180 x H 75 cm
Ø 70 7/8" x H 29 1/2"

brenta

Simone Bonanni



Sedia con struttura in legno massello disponibile nelle finiture Tabacco o laccato Nero a poro aperto. Seduta e schienale rivestiti in pelle o tessuto.

Chair with solid wood structure, available in Tobacco or in open pore Black laquered finish. Seat and backrest are upholstered in leather or fabric.

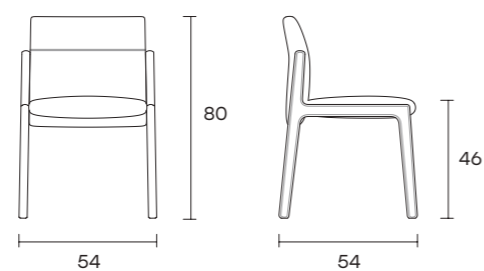

L 54 x P 54 x H 80 cm
L 21 1/4" x W 21 1/4" H 31 1/2"

Struttura in legno Wood structure



NE
Nero
Black



TA
Tabacco
Tobacco

Per i rivestimenti disponibili, far riferimento al campionario pelli e tessuti (p. 122)

For available upholstery, please refer to the leather and fabric samples (p.122)

still

Controvento



Specchio da parete o da terra con cornice in vetro da 6 mm fuso a gran fuoco e retroargentato, disponibile nelle finiture standard, bronzo o fumè. specchio piano da 5 mm. Telaio posteriore in metallo verniciato. Possibilità di appendimento in diverse posizioni.

Hanging or leaning mirror with 6 mm-thick high-temperature fused and back-silvered glass frame, available in standard, bronze or smoked finishes. 5 mm-thick flat mirror. Painted metal rear frame. It can be hung in various positions.

ST1200

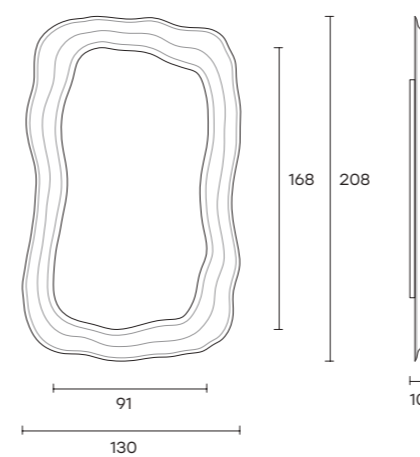

L 130 x P 10 x H 208 cm
L 51 3/8" x W 4" H 81 7/8"
L 150 x P 10 x H 150 cm
L 59" x W 4" H 59"
Ø 130 x P 10 cm
Ø 51 3/16" x W 4"

ST1150

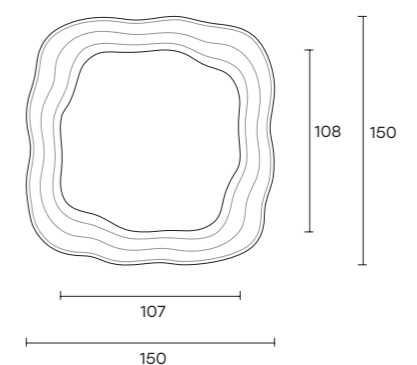

ST1130

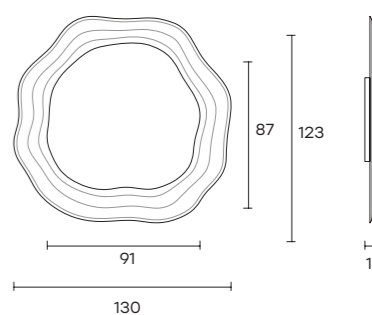

Cornice in vetro fuso _ Fused glass frame



AG
Vetro standard
retroargentato
Back-silvered
standard glass



GR-AG
Vetro fumè
retroargentato
Back-silvered
smoked glass



BR-AG
Vetro bronzo
retroargentato
Back-silvered
bronze glass

istante

Gupica



Specchio da parete con cornice in vetro da 6 mm fuso a gran fuoco, disponibile trasparente nelle finiture bronzo, fumè o verde. La cornice è disponibile anche in vetro fuso retroverniciato con tinte metallizzate. Specchio piano da 5 mm. Telaio posteriore in metallo.

Wall mirror with 6 mm-thick high-temperature fused glass frame, available transparent in bronze, smoked or green finishes. Frame available also in back-painted fused glass, with metallic paints. 5 mm-thick flat mirror. Metal rear frame.

IST54

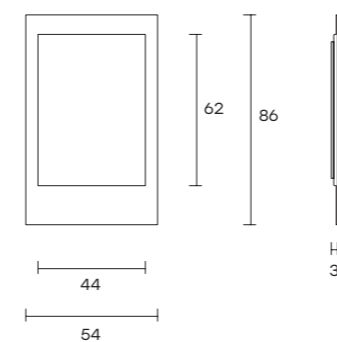

IST72

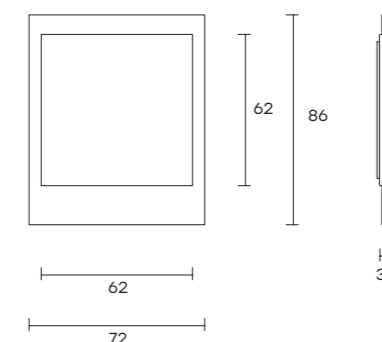

IST108

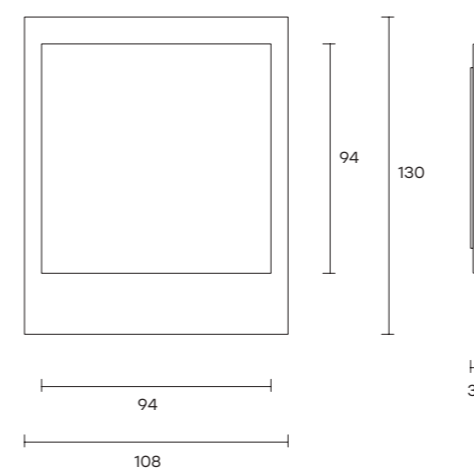

IST68

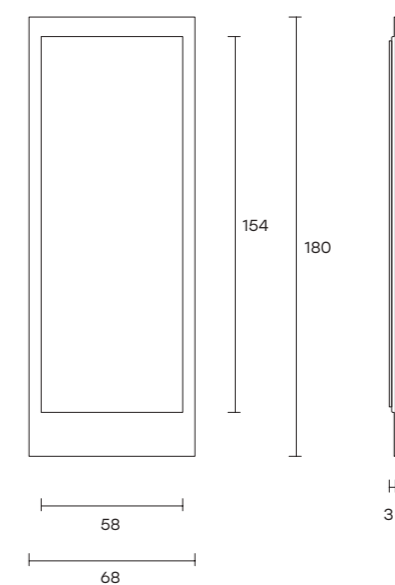

Cornice in vetro fuso
Fused glass frame



Vetro Bronzo
Bronze glass

Vetro Fumè
Smoked glass

Vetro Verde
Green Glass

Cornice in vetro fuso retroverniciato
Fused and back-painted glass frame

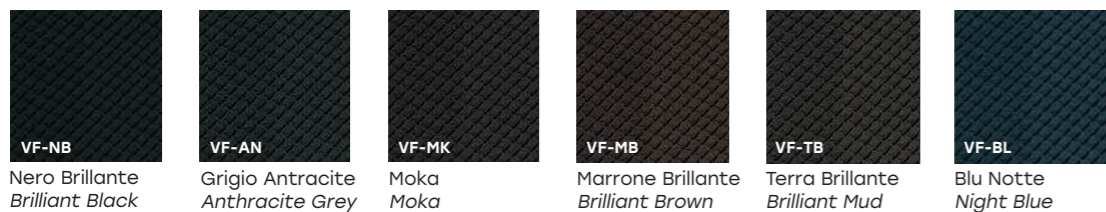

Nero Brillante
Brilliant Black

Grigio Antracite
Anthracite Grey

Moka
Moka

Marrone Brillante
Brilliant Brown

Terra Brillante
Brilliant Mud

Blu Notte
Night Blue

L 54 x P 3 x H 86 cm
L 21 1/4" x W 1 3/16" H 33 7/8"
L 72 x P 3 x H 86 cm
L 28 3/8" x W 1 3/16" H 33 7/8"
L 108 x P 3 x H 130 cm
L 42 1/2" x W 1 3/16" H 51 3/16"
L 68 x P 3 x H 180 cm
L 26 3/4" x W 1 3/16" H 70 7/8"

segesta bar

Studio Klass



Madia con scocca esterna in legno laccato Grigio Vulcano, Greige Metallizzato, oppure Moka. Top in legno laccato in tinta con la struttura esterna (spessore 14 mm), oppure in Marmo (spessore 40 mm), oppure in legno impiallacciato (spessore 40 mm). Base e piedini in acciaio verniciato nero. Ante in vetro da 6 mm temperato nelle varianti liscio, fuso oppure acidato, disponibili in diverse finiture e verniciature. I vetri delle ante sono fissati ad un telaio di alluminio in finitura nera, con cerniere a scomparsa. Struttura interna in nobilitato a trama plissettata, attrezzata con: ripiano in vetro da 12 mm temperato; ripiano portabottiglie in legno; frigorifero da 50L, di cui 3,6L adibiti a cella freezer. Il frigorifero è sostituibile da un sistema di 3 cassetti. Sistema di illuminazione a LED integrato nella struttura interna (opzionale).

Cupboard with external structure in lacquered wood in Vulcan Grey, Metallic Greige, or Moka finish. Top available in the same lacquered wood finish of the external structure (14 mm thick), or in marble (40 mm thick), or in veneered wood (40 mm thick). Base and feet in black lacquered metal. Relevant doors in flat, fused or acid-etched tempered glass (6 mm. thick), available in various finishes and lacquers. The glass doors are fastened to an aluminium frame in black finish through hidden hinges. Internal structure in pleated-texture melamine, equipped with: a 12 mm tempered glass shelf; a wooden bottle rack shelf; a 50 L refrigerator, including a 3.6 L freezer compartment. The refrigerator can be replaced with a system of 3 drawers. Optional LED lighting system integrated within the internal structure.

SEF115
con frigorifero / with refrigerator

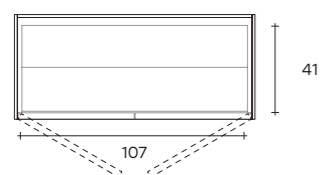
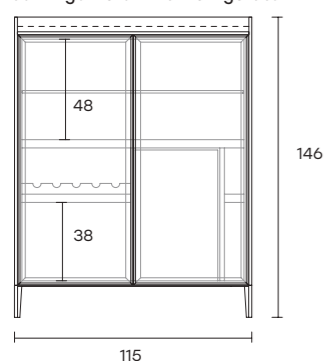

SEC115
con cassetti / with drawers

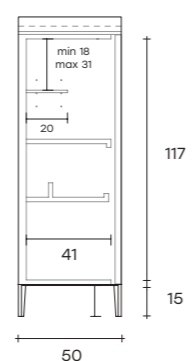
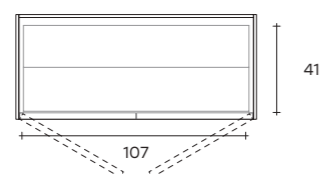

L 115 x P 50 x H 145 cm
L 45 1/4" x W 19 1/16" H 57"

Scocca esterna e top in legno laccato _ External structure and top in laquered wood

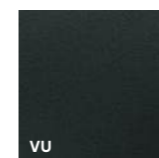

Grigio Vulcano
Vulkan grey

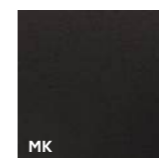

Moka metallizzato
Metallic Moka

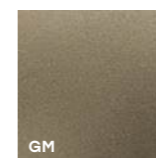

Greige metallizzato
Metallic greige

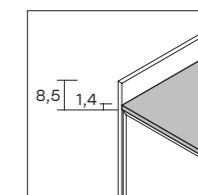

Ante in vetro piano _ Flat glass doors



Fumè
Smoked

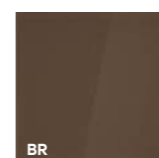

Bronzo
Bronze

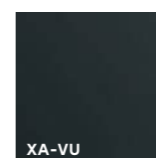

Extralight acidato
retroverniciato
Grigio Vulcano
Acid-etched
extralight,
Vulcan Grey back-
painted

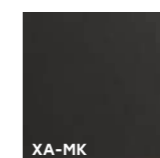

Extralight acidato
retroverniciato
Moka
Acid-etched
extralight, Moka
back-painted

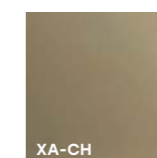

Extralight acidato
retroverniciato
Champagne
Acid-etched
extralight, Champagne
back-painted

Ante in vetro fuso _ Fused glass doors

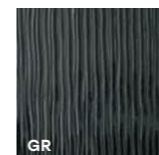

Fumè
Smoked

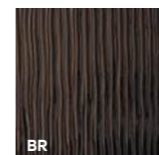

Bronzo
Bronze



Retroverniciato
Grigio Vulcano
Vulcan Grey
back-painted

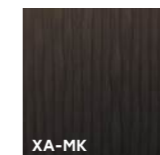

Retroverniciato
Moka
back-painted

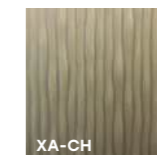

Retroverniciato
Champagne
Champagne
back-painted

Top in marmo _ Marble top



Grigio Carnico
Carnico Grey

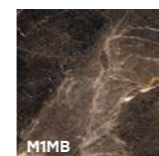

Mystic Brown
Mystic Brown



Manhattan
Manhattan

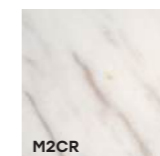

Calacatta Royal
Calacatta Royal

Top in legno impiallacciato _ Veneered wood top



Termotrattato
Nero
Heat-treated
Black finish



Noce Canaletto
tinto Tabacco
Canaletto Walnut
Tobacco finish

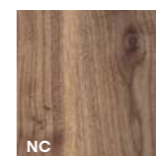

Noce Canaletto
Canaletto Walnut

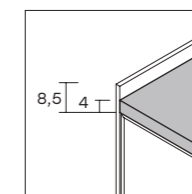

asteroids

Arik Levy



Tavolino con piano sagomato in vetro da 10 mm fuso a gran fuoco, retroverniciato con tinte metallizzate. Base in vetro da 10 mm fuso a gran fuoco e curvato, retroverniciato con tinte metallizzate in tinta con il piano. Piano disponibile anche in marmo, spessore 20 mm.

Coffee table with shaped top in 10 mm high-temperature fused glass, back-painted with metallic colours. Base in 10 mm high-temperature fused and curved glass, back-painted with metallic colours matching the top. Top also available in marble, 20 mm thick.

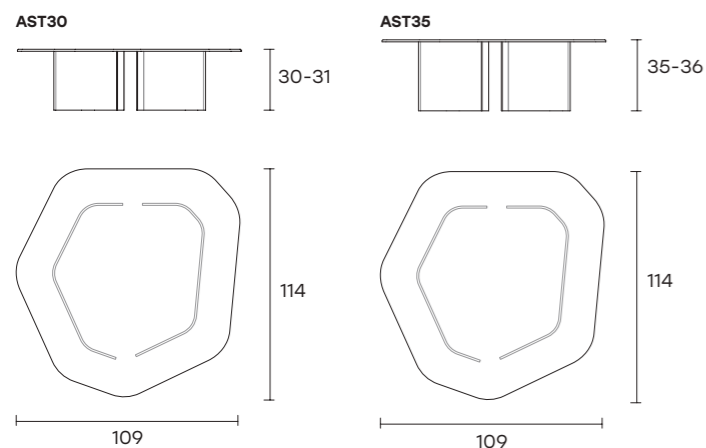

L 114 x P 109 x H 30 cm
L 44 7/8" x W 43" H 11 13/16"
L 114 x P 109 x H 35 cm
L 44 7/8" x W 43" H 13 3/4"

Piano e base in vetro fuso retroverniciato _ Fused and back-painted glass top and base



Nero Brillante
Brilliant Black

Grigio Antracite
Anthracite Grey

Moka
Moka

Marrone Brillante
Brilliant Brown

Terra Brillante
Brilliant Mud

Blu Notte
Night Blue

**FINITURE NON STANDARD
SU RICHIESTA
NON-STANDARD FINISHES
ON REQUEST**



Marrone Ramato
Copper Brown

Champagne
Champagne

Verde Salvia
Sage Green

Cipria
Powder Pink

Piano in marmo _ Marble top



Grigio Carnico
Carnico Grey

Mystic Brown
Mystic Brown

Manhattan
Manhattan

Calacatta Royal
Calacatta Royal

onair

Ceriani Szostak



Poltroncina con struttura interna in legno multistrato. Imbottitura di seduta e schienale in poliuretano. Base in vetro curvato da 10 mm. Piedini in alluminio in finitura spazzolato oppure anodizzato nero. La poltroncina può essere rivestita in pelle o in tessuto: fare riferimento alle categorie di rivestimento disponibili. Struttura sfoderabile solo nelle versioni in tessuto.

Armchair with internal structure in multilayered wood. Seat and back cushion in polyurethane. Curved glass base, 10 mm thick. Aluminium feet in brushed or black finish. The armchair can be upholstered in leather or fabric, please refer to the available upholstery categories. Structure is removable in fabric versions only.

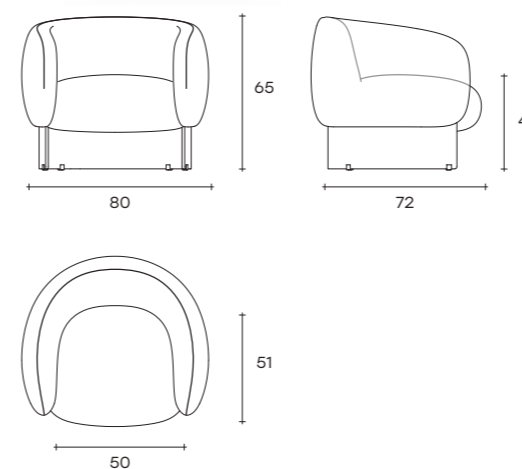

L 80 x P 72 x H 65 cm
L 31 1/2" x W 28 3/8" H 25 9/16"

Base in vetro curvato (su richiesta) _ Curved glass base (on request)



Vetro extralight
Extralight glass

Vetro fumé
Smoked glass

Vetro bronzo
Bronze glass

Per i rivestimenti disponibili, far riferimento al campionario pelli e tessuti (p. 122)

For available upholstery, please refer to the leather and fabric samples (p. 122)

pelli / leathers

SILKY

cat. PL-2



9010
Botticino

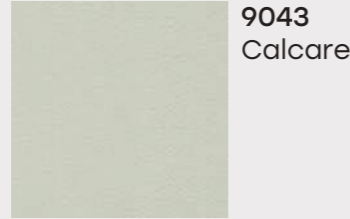

9043
Calcare



9018
Bird

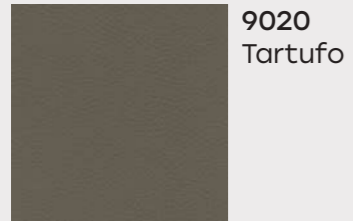

9020
Tartufo

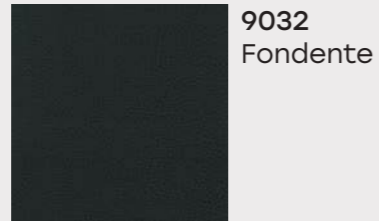

9032
Fondente



9000
Latte



9015
Carrara



9025
Razza

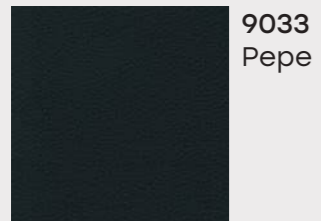

9033
Pepe

NUBUCK

cat. PL-5



2118
Perla
Pearl Grey



2116
Castagna
Chestnut Brown



2114
Testa di Moro
Dark Brown

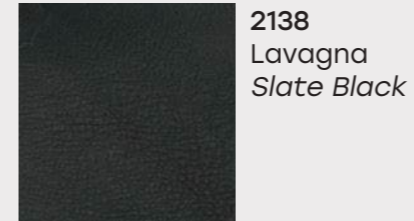

2138
Lavagna
Slate Black

tessuti / fabrics

STARLIGHT

cat. TX-2



MOONLIGHT

cat. TX-2



tessuti / fabrics

BOUCLÉ

cat. TX-3

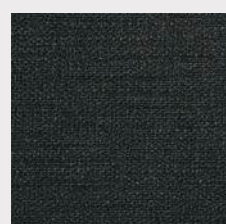
**01**
Avorio**02**
Agata**03**
Quarzo**05**
Argilla**04**
Pietra**08**
Basalto**09**
Ardesia**10**
Onice**08/1**
Acquamarina**09/1**
Zaffiro

TEDDY BEAR

cat. TX-4

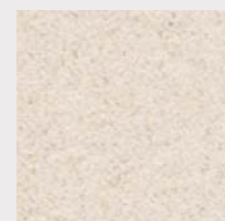
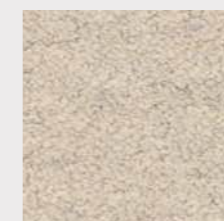
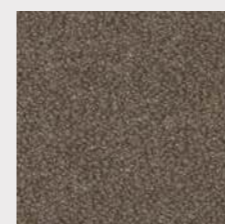
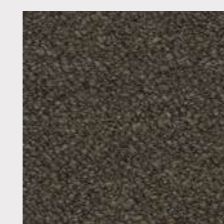
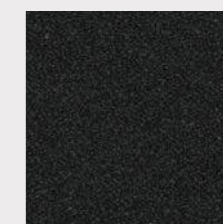
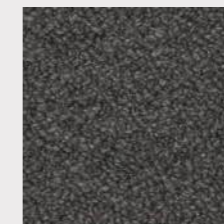
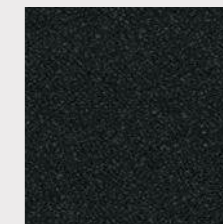
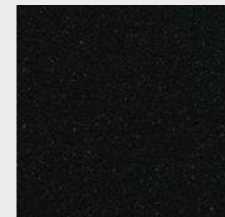
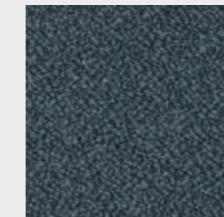
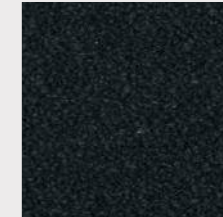
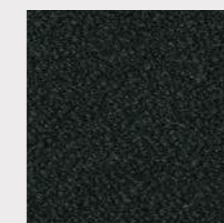
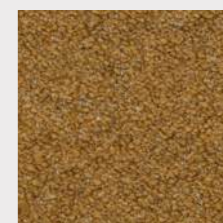
**01/1**
Bianco**01/2**
Sabbia**05/10**
Quarzo**05/121**
Noce**07/11**
Argilla**98/16**
Moka**02/22**
Cemento**09/12**
Piombo**98/21**
Antracite**98/36**
Nero**09/92**
Cielo**98/20**
Blu Notte**02/26**
Salvia**98/18**
Foresta**05/6**
Ocra**07/24**
Ruggine

art direction
adele martelli

graphic design
acanto comunicazione

photography and post production
studio leon
culto productions

rendering images
reality studio
controvento

marketing project
daniele livi

coordination and logistics
lorenzo marzoli

June 2026

Fiam Italia
Via Ancona 1/b
61010 Tavullia (PU)
Italy

T: +39 0721 20051
F: +39 0721 202432
info@fiamitalia.it

#fiamitalia

follow us on



